

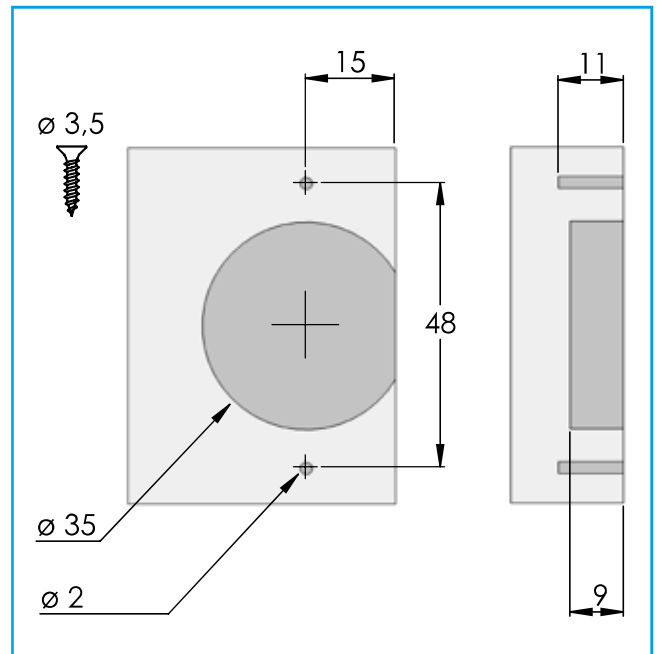

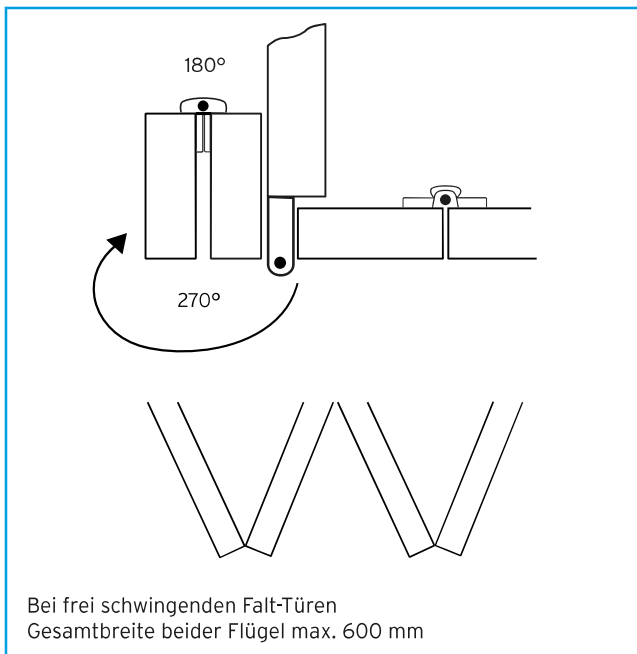

FALT-TÜR-SCHARNIER

- Für frei schwingende und geführte falt-Türen
- Doppelt wirkende Edelstahlfeder stabilisiert beide Endlagen
- Höhenverstellung ± 1 mm
- faltwinkel 180°
- Fuge 0 - 10 mm
- 3 mm Fuge vormontiert



					NORM
2002 N	50	180°	0 - 10	ab 13	EN
vernickelt	Oberflächen schwarz auf Anfrage				

Anzahl Scharniere pro Tür

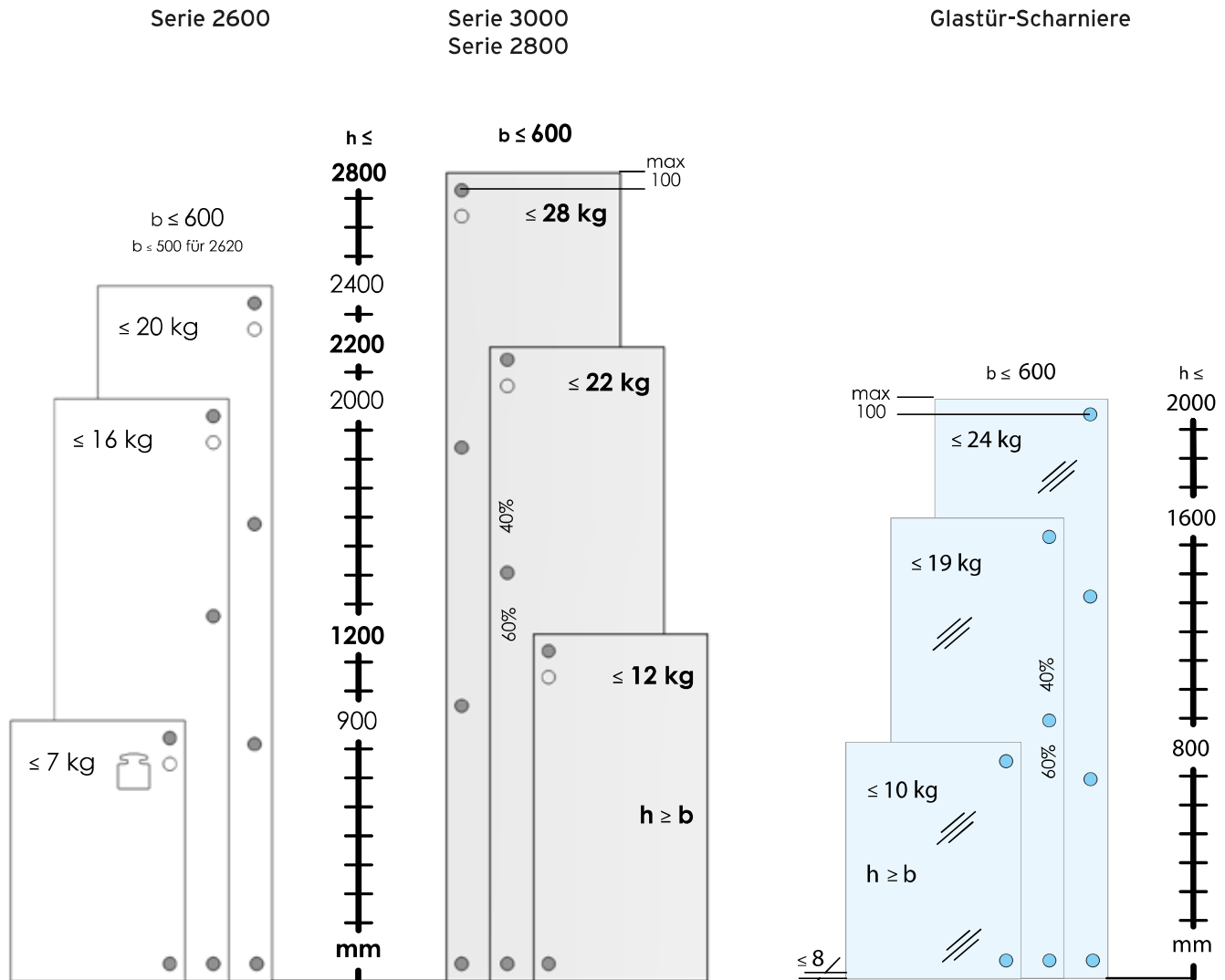

PRÄMETA-Objekt-Scharniere zertifiziert nach ANSI Grade 1 und EN 15570 Level 3

		ANSI Grade 1 (international höchste Norm für Möbelscharniere)	EN 15570 Level 3	EN 15570 Level 2
Dauerprüfung				
Türgewicht	kg	18	7	7
Zahl der Zyklen		100.000	80.000	40.000
Absenkung der Tür	mm	0,76	3,0	3,0
Sicherheitsprüfung				
Zusatzgewicht	kg	72	30	20
Absenkung der Tür	mm	0,76	kein Türabsturz	kein Türabsturz