

# Side hung mounting with a WMU 836

## Seitliche Montage mit einem WMU 836

### Sidehængt montage med en WMU 836

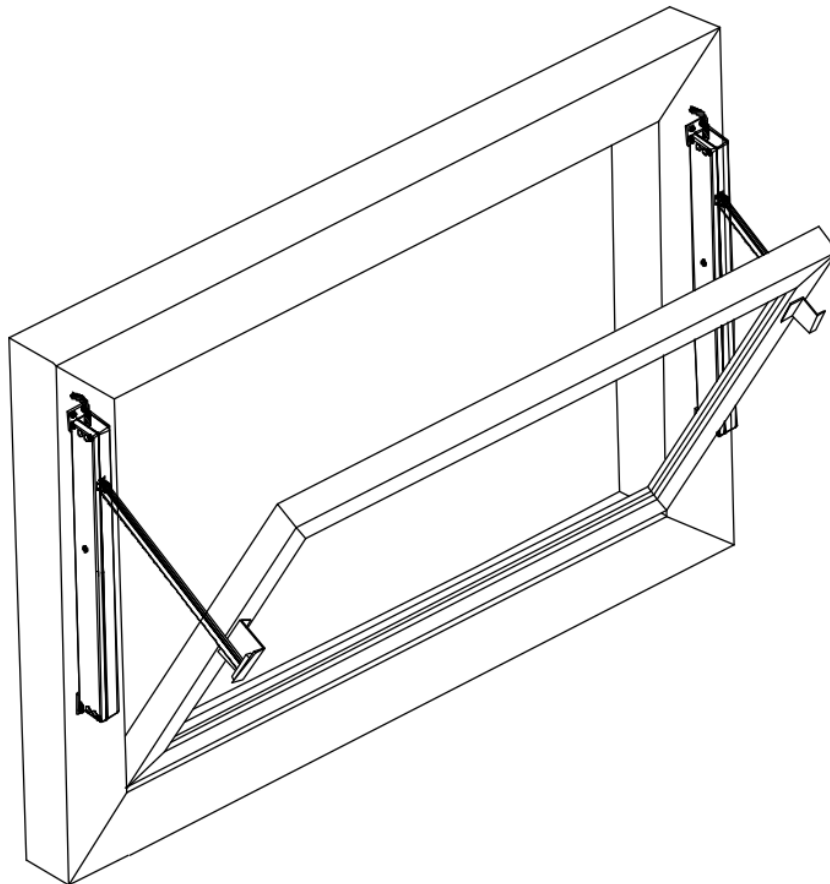

## Table of contents

EN		
1.	Frame mounting .....	2
2.	Sash mounting.....	3
DE		
3.	Blendrahmen Montage .....	4
4.	Flügel Montage.....	5
DK		
5.	Karmmontage .....	6
6.	Rammemontage .....	7

**DK** +45 4567 0300  
**UK** +44 (0) 1536 510990  
**DE** +49 (0) 5221 6940 -500 Vertrieb / -650 Technik  
**CH** +41 62 89 22 22  
**Other markets** +45 4567 0300

info.dk@windowmaster.com  
 info@windowmaster.co.uk  
 info@windowmaster.de  
 info@windowmaster.ch  
 info@windowmaster.com

[www.windowmaster.com](http://www.windowmaster.com)

# 1. Frame mounting

**List of articles:**

- 2 x actuators WMU 836-2 xxxx
- 2 x bracket set WAZ 101 0101
- Consisting of:
  - 2 x chain bracket WAB 836E
  - 2 x actuator bracket WAB 824
  - 2 x z-bracket WAB 825
  - 2 x cable ducts
  - 2 x brass sleeves

The actuator must be mounted so that the cable extraction is at the top.

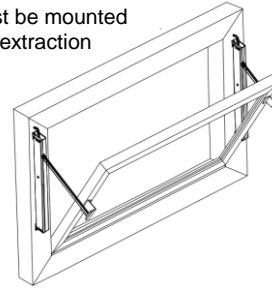

The brass sleeves must be mounted in the chain bracket as shown.

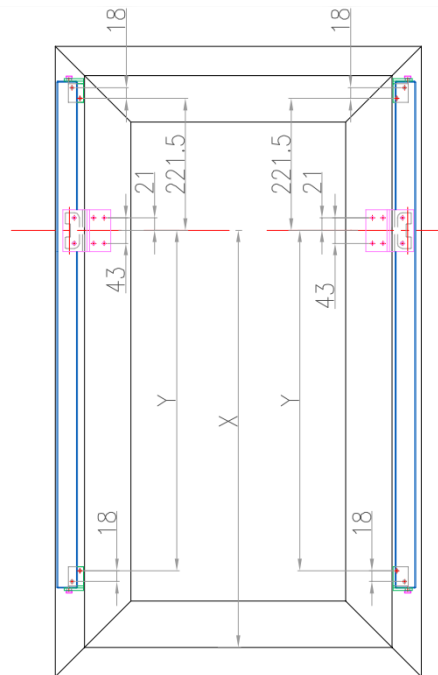
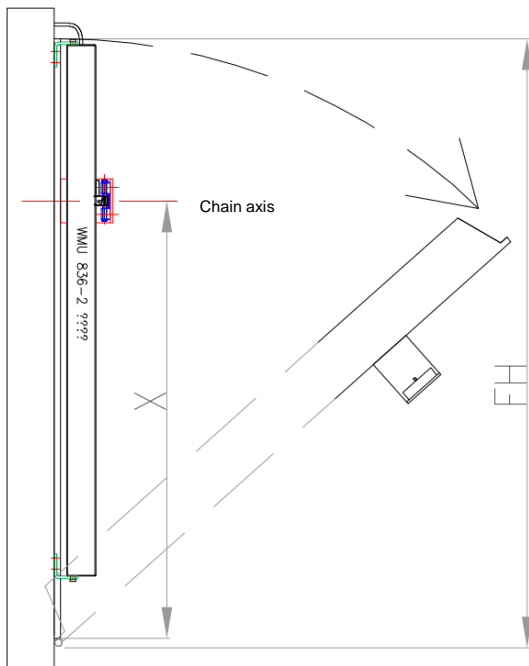
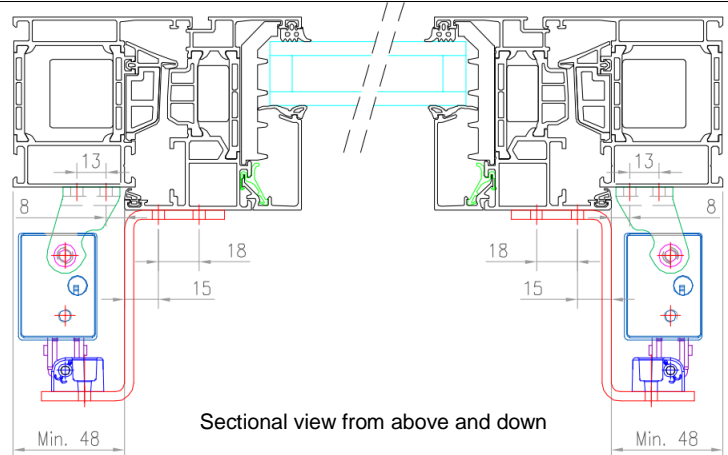
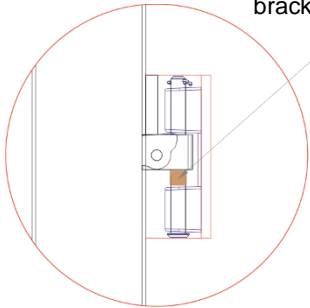

- 400mm chain length = min WH: 570mm & x = min 310mm = max opening angle ~76°
- 600mm chain length = min WH: 673mm & x = min 413mm = max opening angle ~90°
- 800mm chain length = min WH: 815mm & x = min 555mm = max opening angle ~90°
- 1000mm chain length = min WH: 960mm & x = min 700mm = max opening angle ~90°

- 400mm chain length → Y = 271,5mm
- 600mm chain length → Y = 371,5mm
- 800mm chain length → Y = 471,5mm
- 1000mm chain length → Y = 571,5mm

Opening angle (a) =  $2 \cdot \sin^{-1} \left( \frac{\text{chain length} / 2}{\sqrt{(61,5)^2 + (7+x)^2}} \right)$

Load per actuator =  $\frac{(\text{frame weight} \cdot \sin(a - \tan^{-1}(57/((WH/2) + 7)))) \cdot (((WH/2) + 7)^2 + 57^2)^{0,5}}{\cos(a/2) \cdot (11,5^2 + (7+x)^2)^{0,5}}$

Max load per actuator ≤ 30Kg

## 2. Sash mounting

**List of articles:**

2 x actuators WMU 836-2 xxxx

2 x bracket set WAZ 102 0101

Consisting of:

2 x chain bracket WAB 811

2 x actuator bracket WAB 836P

2 x cable ducts

The actuator must be mounted so that the cable extraction is at the top.

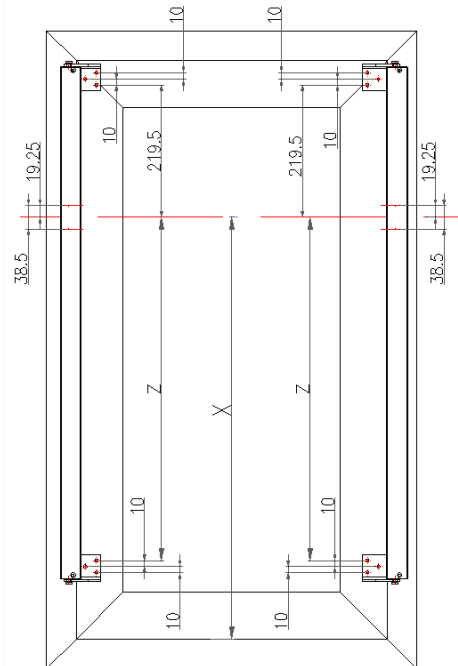
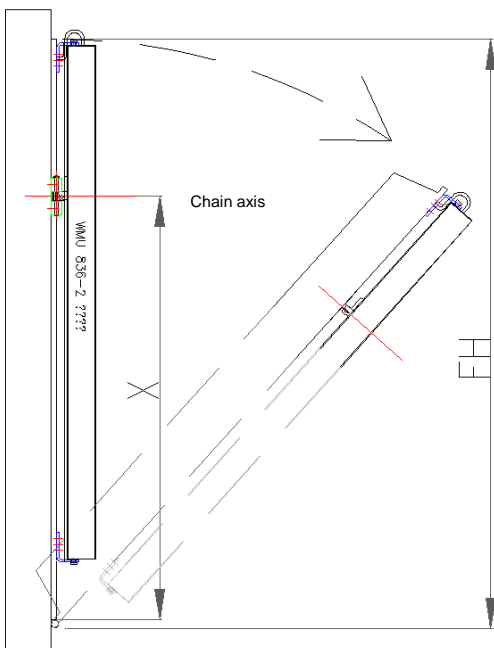
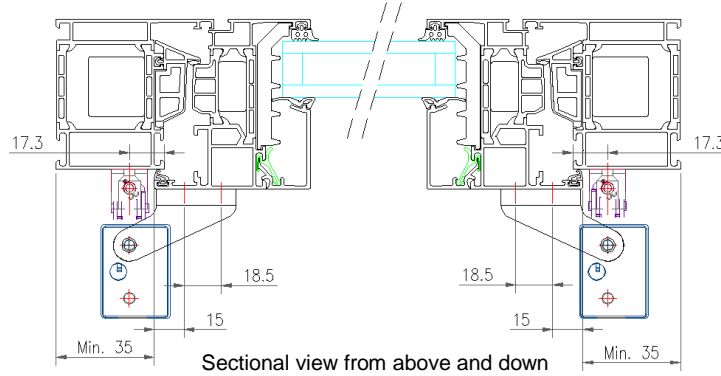
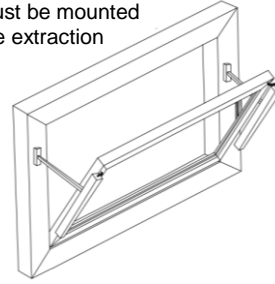

- 400mm chain length = min WH: 570mm & x = min 310mm = max opening angle ~78°
- 600mm chain length = min WH: 677mm & x = min 417mm = max opening angle ~90°
- 800mm chain length = min WH: 820mm & x = min 560mm = max opening angle ~90°
- 1000mm chain length = min WH: 960mm & x = min 700mm = max opening angle ~90°

- 400mm chain length → Z = 269,5mm
- 600mm chain length → Z = 369,5mm
- 800mm chain length → Z = 469,5mm
- 1000mm chain length → Z = 569,5mm

$$\text{Opening angle } (a) = 2 \cdot \sin^{-1} \left( \frac{\text{chain length} / 2}{\sqrt{(11,5)^2 + (7+x)^2}} \right), 0,5$$

$$\text{Load per actuator} = \frac{(\text{frame weight} \cdot \sin(a - (\tan^{-1}(57/((WH/2) + 7)))) \cdot \sqrt{((WH/2) + 7)^2 + 57^2})^{0,5}}{\cos(a/2) \cdot \sqrt{(11,5)^2 + (7+x)^2}}^{0,5}$$

Max load per actuator ≤ 30Kg

### 3. Blendrahmen Montage

**Artikelliste:**

2 x Antriebe WMU 836-2 xxxx

2 x Beschlagsätze WAZ 101 0101

Bestehen aus:

2 x Kettenbeschlag WAB 836E

2 x Antriebsbeschlag WAB 824

2 x Z-Beschlag WAB 825

2 x Kabelkanäle

2 x Messing Hülsen

Der Antrieb muss so montiert werden, dass der Kabelaustritt oben ist.

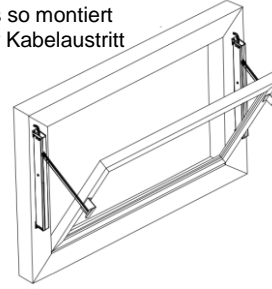

Bitte die beiliegende Messinghülse wie dargestellt im Kettenbeschlag montiere.

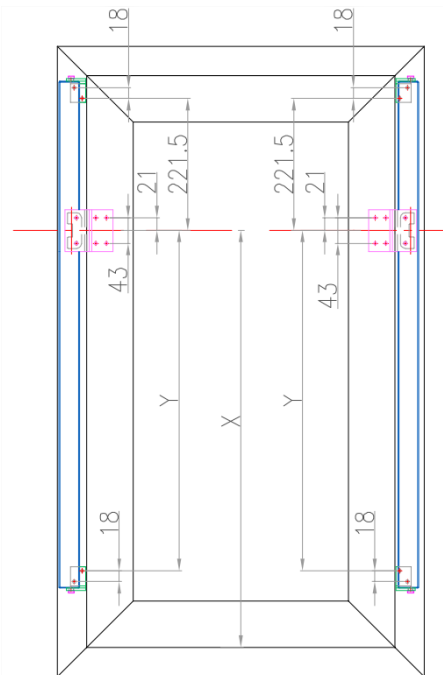
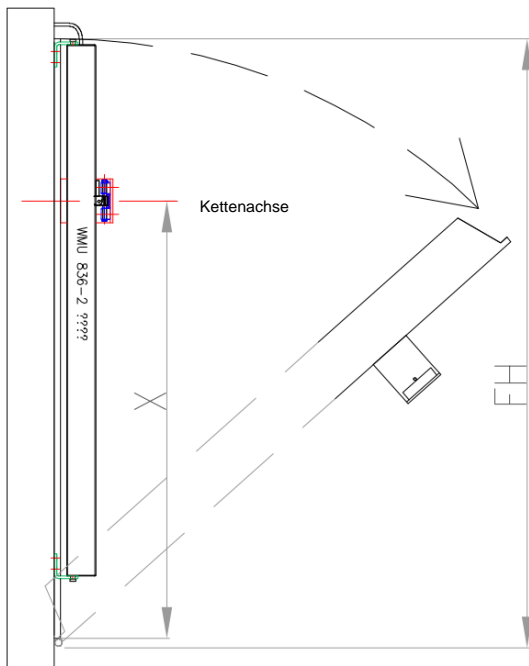
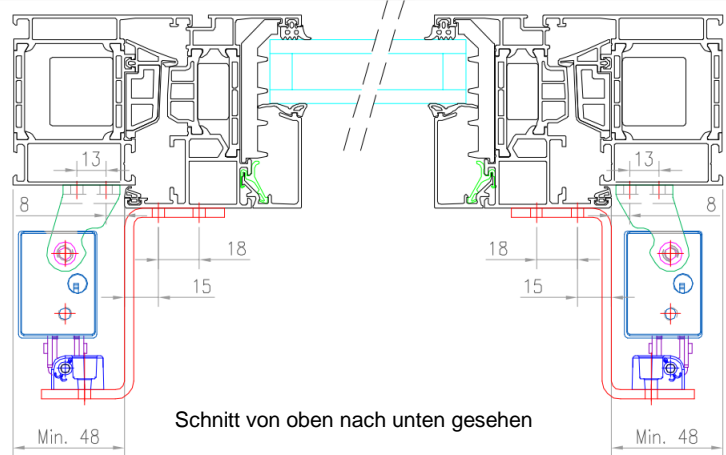
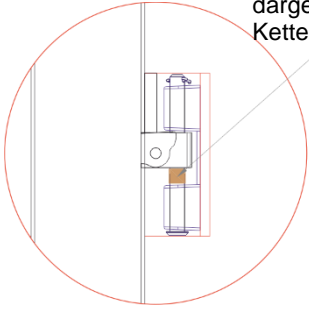

- 400mm Hub = Min FH: 570mm & x = Min 310mm = Max Öffnungswinkel ~76°
- 600mm Hub = Min FH: 673mm & x = Min 413mm = Max Öffnungswinkel ~90°
- 800mm Hub = Min FH: 815mm & x = Min 555mm = Max Öffnungswinkel ~90°
- 1000mm Hub = Min FH: 960mm & x = Min 700mm = Max Öffnungswinkel ~90°

- 400mm Hub → Y = 271,5mm
- 600mm Hub → Y = 371,5mm
- 800mm Hub → Y = 471,5mm
- 1000mm Hub → Y = 571,5mm

$$\text{Öffnungswinkel } (a) = 2 \cdot \sin^{-1} \left( \frac{(\text{Hub}/2)}{\sqrt{(61,5)^2 + (7+x)^2}} \right)$$

$$\text{Belastung pro Antrieb} = \frac{(\text{Flügelgewicht} \cdot \sin(a - (\tan^{-1}(57/((\text{FH}/2) + 7))))}{\cos(a/2)} \cdot \frac{((\text{FH}/2) + 7)^2 + 57^2}{\sqrt{(61,5)^2 + (7+x)^2}}$$

Max Belastung pro Antrieb ≤ 30Kg

# 4. Flügel Montage

**Artikelliste:**

2 x Antriebe WMU 836-2 xxxx

2 x Beschlagsätze WAZ 102 0101

Bestehen aus:

2 x Kettenbeschlag WAB 811

2 x Antriebbeschlag WAB 836P

2 x Kabelkanäle

Der Antrieb muss so montiert werden, dass der Kabelaustritt oben ist.

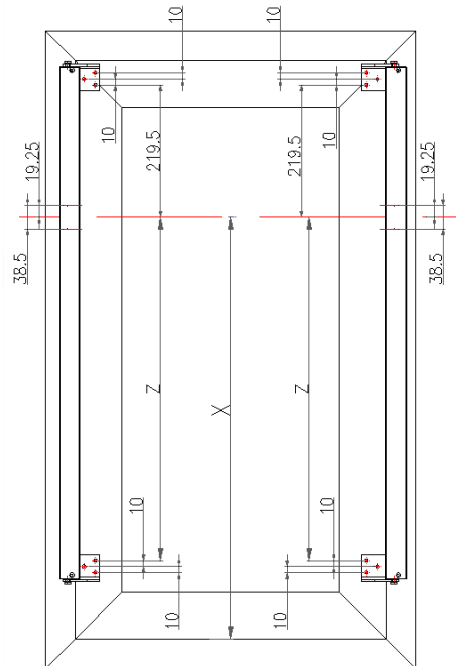
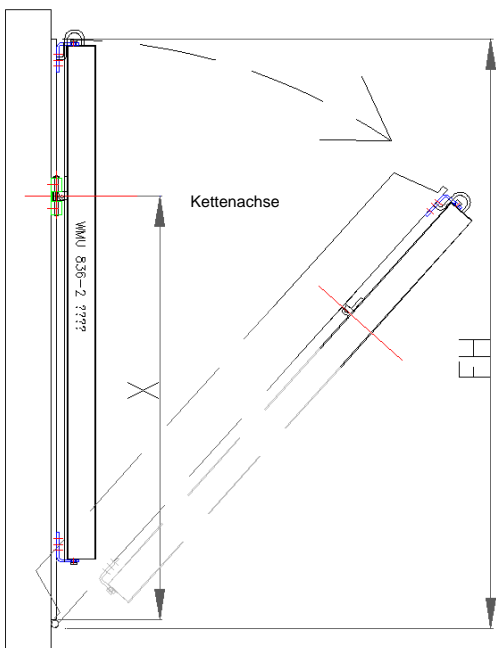
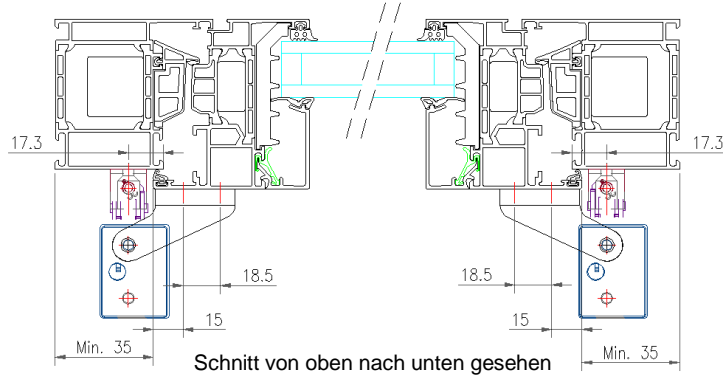
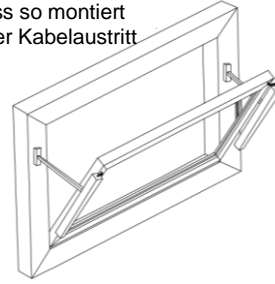

- 400mm Hub = Min FH: 570mm & x = Min 310mm = Max Öffnungswinkel ~78°
- 600mm Hub = Min FH: 677mm & x = Min 417mm = Max Öffnungswinkel ~90°
- 800mm Hub = Min FH: 820mm & x = Min 560mm = Max Öffnungswinkel ~90°
- 1000mm Hub = Min FH: 960mm & x = Min 700mm = Max Öffnungswinkel ~90°

- 400mm Hub → Z = 269,5mm
- 600mm Hub → Z = 369,5mm
- 800mm Hub → Z = 469,5mm
- 1000mm Hub → Z = 569,5mm

Öffnungswinkel (a) =  $2 \cdot \sin^{-1} \left( \frac{\text{Hub}/2}{\sqrt{(11,5)^2 + (7+x)^2}} \right)^{0,5}$

Belastung pro Antrieb =  $\frac{\text{Flügelgewicht} \cdot \sin(a - \tan^{-1}(57/((\text{FH}/2) + 7)))}{\cos(a/2) \cdot \sqrt{(11,5)^2 + (7+x)^2}}^{0,5}$

Max Belastung pro Antrieb ≤ 30Kg

# 5. Karmmontage

**Artikelliste:**

2 x motorer WMU 836-2 xxxx

2 x Beslagsæt WAZ 101 0101

Bestående af:

2 x kædebeslag WAB 836E

2 x motorbeslag WAB 824

2 x z-beslag WAB 825

2 x kabelkanaler

2 x messing hylstre

Motoren monteres således, at kabeludtrækket er øverst.

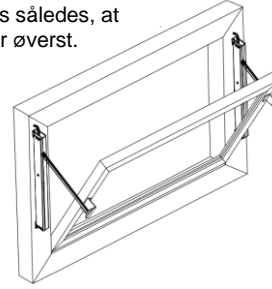

Messing hylstre skal monteres i kædebeslaget som vist.

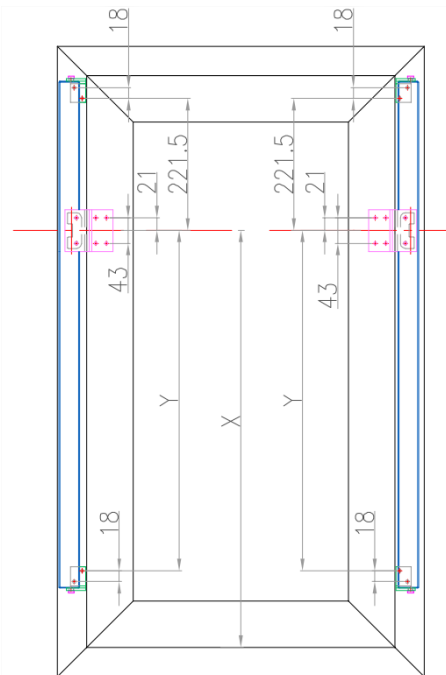
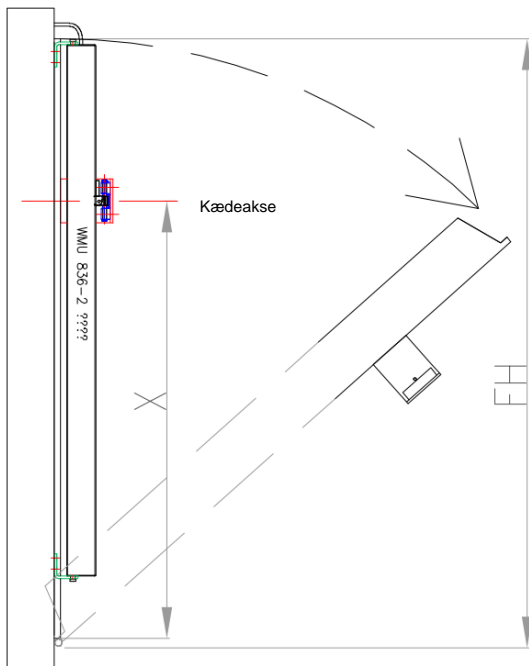
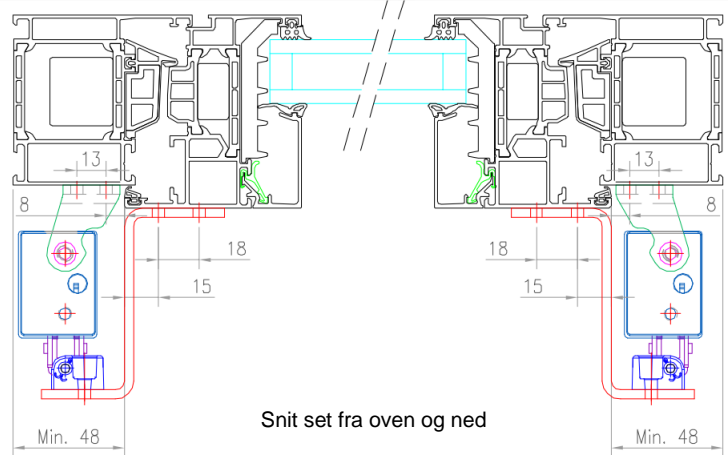
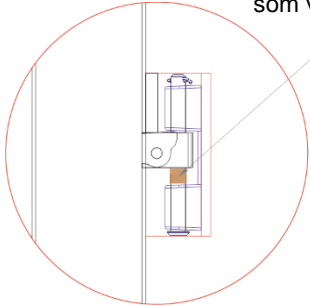

- 400mm slaglængde = min VH: 570mm & x = min 310mm = max åbningsvinkle ~76°
- 600mm slaglængde = min VH: 673mm & x = min 413mm = max åbningsvinkle ~90°
- 800mm slaglængde = min VH: 815mm & x = min 555mm = max åbningsvinkle ~90°
- 1000mm slaglængde = min VH: 960mm & x = min 700mm = max åbningsvinkle ~90°

- 400mm slaglængde → Y = 271,5mm
- 600mm slaglængde → Y = 371,5mm
- 800mm slaglængde → Y = 471,5mm
- 1000mm slaglængde → Y = 571,5mm

Åbningsvinkle (a) =  $2 \cdot \sin^{-1} \left( \frac{\text{slaglængde}}{2} / \left( (61,5)^2 + (7+x)^2 \right)^{0,5} \right)$

Belastning per motor =  $\frac{\text{rammevægt} \cdot \sin(a - (\tan^{-1}(\frac{57}{(VH/2) + 7}))) \cdot \left( \left( \frac{VH}{2} \right)^2 + 7^2 + 57^2 \right)^{0,5}}{\cos(a/2) \cdot \left( 11,5^2 + (7+x)^2 \right)^{0,5}}$

Max belastning per motor ≤ 30Kg

## 6. Rammemontage

### Artikelliste:

- 2 x motorer WMU 836-2 xxxx
- 2 x beslagsæt WAZ 102 0101
- bestående af:
  - 2 x kædebeslag WAB 811
  - 2 x motorbeslag WAB 836P
  - 2 x kabelkanaler

Motoren monteres således, at kabeludtrækket er øverst.

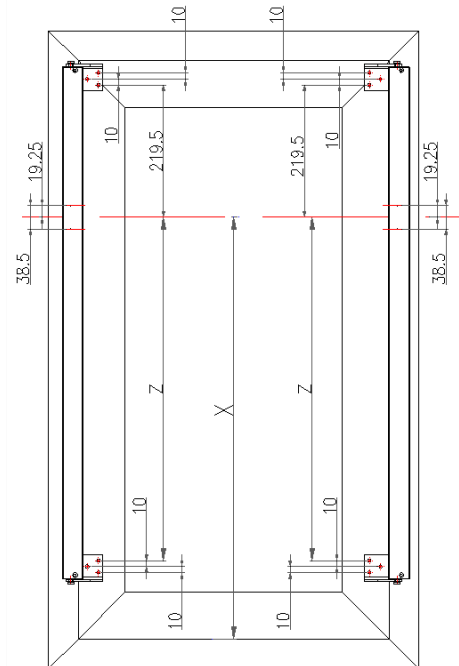
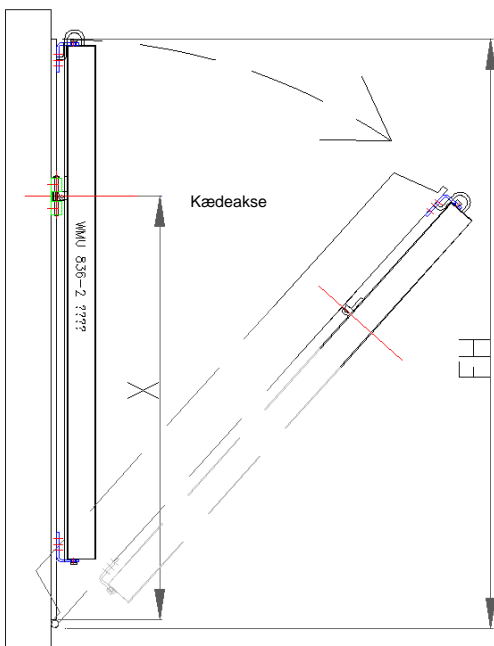
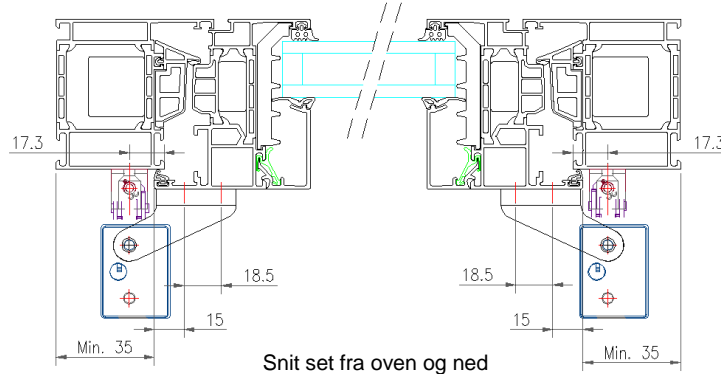
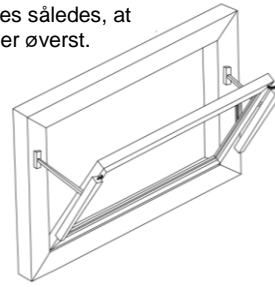

- 400mm slaglængde = min VH: 570mm & x = min 310mm  
= max åbningsvinkel ~78°
- 600mm slaglængde = min VH: 677mm & x = min 417mm  
= max åbningsvinkel ~90°
- 800mm slaglængde = min VH: 820mm & x = min 560mm  
= max åbningsvinkel ~90°
- 1000mm slaglængde = min VH: 960mm & x = min 700mm  
= max åbningsvinkel ~90°

- 400mm slaglængde → Z = 269,5mm
- 600mm slaglængde → Z = 369,5mm
- 800mm slaglængde → Z = 469,5mm
- 1000mm slaglængde → Z = 569,5mm

$$\text{Åbningsvinkel (a)} = 2 \cdot \sin^{-1} \left( \frac{\text{slaglængde}/2}{\left( (11,5)^2 + (7+x)^2 \right)^{0,5}} \right)$$

$$\text{Belastning per motor} = \frac{\text{rammevægt} \cdot \sin(a - \tan^{-1}(57/((VH/2) + 7))) \cdot \left( ((VH/2) + 7)^2 + 57^2 \right)^{0,5}}{\cos(a/2) \cdot \left( (11,5)^2 + (7+x)^2 \right)^{0,5}}$$

Max belastning per motor ≤ 30Kg