



<b>TEST REPORT</b> <b>EN 1906</b> <b>Building hardware –</b> <b>Lever handles and knob furniture – Requirements and test methods</b>									
Report reference No. ....:	141212054GZU-007								
Tested by (name and signature).....:	Credy Chen <i>Credy Chen</i>								
Approved by (name and signature) ...:	Blusea Dong <i>Blusea Dong</i>								
Date of issue.....:	July 20, 2016								
Contents .....	Total test report 11 pages including: Report text: 6 pages Appendix A for product photos and drawings: 4 pages Revision Page: 1 page								
<b>Testing Laboratory name</b> .....	Intertek Testing Services Shenzhen Ltd. Guangzhou Branch								
Address.....:	Block E, No.7-2 Guang Dong Software Science Park, Caipin Road, Guangzhou Science City, GETDD, Guangzhou, China								
Testing location.....:	Same as above								
<b>Applicant's name</b> .....	NICKAL S.A.								
Address.....:	Chemin Champs Lovats 5, 1400 Yverdon-les-Bains, Switzerland								
<b>Test specification</b>									
Standard .....	EN 1906:2012								
Non-standard test method .....	N.A.								
<b>Test Report Form No.</b> .....									
TTRF Originator.....:	Intertek Testing Services Shenzhen Ltd. Guangzhou Branch								
Master TTRF.....:	Dated 2015-12								
<b>Test item description</b> .....									
Trademark .....	—								
Model and/or type reference .....	5074.0800/FS; 5559.0800/FS; 5557.0800/FS								
Manufacturer.....:	Wellcom International Ltd.								
Rating .....	<table border="1"><tr><td>3</td><td>7</td><td>—</td><td>—</td><td>1</td><td>4</td><td>0</td><td>U</td></tr></table>	3	7	—	—	1	4	0	U
3	7	—	—	1	4	0	U		
<b>Summary of testing</b>									
The submitted samples <b>COMPLIED</b> with all applicable mechanical clauses of EN 1906:2012 for its classification.									

Test item particulars																																
Classification of installation and use.....: Intend use in public high frequency used doors																																
<p><b>Test case verdicts</b></p> <p>- test case does not apply to the test object..... : N/A</p> <p>- test object does meet the requirement..... : P (Pass)</p> <p>- test object does not meet the requirement..... : F (Fail)</p>																																
<p><b>Testing</b></p> <p>Date of receipt of test item..... : November 29, 2014, March 07, 2015 and March 23, 2016</p> <p>Date (s) of performance of tests ..... : December 12, 2014 to June 15, 2016</p>																																
<p><b>General remarks</b></p> <p>This report is for the exclusive use of Intertek's Client and is provided pursuant to the agreement between Intertek and its Client. Intertek's responsibility and liability are limited to the terms and conditions of the agreement. Intertek assumes no liability to any party, other than to the Client in accordance with the agreement, for any loss, expense or damage occasioned by the use of this report. Only the Client is authorized to permit copying or distribution of this report and then only in its entirety. Any use of the Intertek name or one of its marks for the sale or advertisement of the tested material, product or service must first be approved in writing by Intertek. The observations and test results in this report are relevant only to the sample tested. This report by itself does not imply that the material, product, or service is or has ever been under an Intertek certification program.</p> <p>"(See remark #)" refers to a remark appended to the report.</p> <p>"(See Appendix #)" refers to an appendix appended to the report.</p> <p>Throughout this report a comma (point) is used as the decimal separator.</p> <p>When determining the test result, measurement uncertainty has been considered.</p>																																
<p><b>General product information:</b></p> <p>3 models of lever handle (listed below), all listed models having the same material and structure, the only difference was the outer shape of handle, the model of '5559.0800/FS' was subjected to full test, # See appendix A product photo and drawing for detailed appearance.</p> <table border="1"> <thead> <tr> <th>Model</th> <th>Lever Handle Drawing#</th> <th>Lever Handle Dimension</th> <th>Material</th> <th>Base plate</th> <th>Door thickness range</th> <th>Spindle size, mm</th> <th>Type</th> </tr> </thead> <tbody> <tr> <td>5074.0800/FS</td> <td>LN199NX</td> <td>Refer to drawing</td> <td>SUS304</td> <td>TLD236ER-P</td> <td>35 to 70mm</td> <td>8*8</td> <td>unsprung</td> </tr> <tr> <td><b>5559.0800/FS</b></td> <td><b>LN216NX</b></td> <td><b>Refer to drawing</b></td> <td><b>SUS304</b></td> <td><b>TLD236ER-P</b></td> <td><b>35 to 70mm</b></td> <td><b>8*8</b></td> <td><b>unsprung</b></td> </tr> <tr> <td>5557.0800/FS</td> <td>LN200NX</td> <td>Refer to drawing</td> <td>SUS304</td> <td>TLD236ER-P</td> <td>35 to 70mm</td> <td>8*8</td> <td>unsprung</td> </tr> </tbody> </table>	Model	Lever Handle Drawing#	Lever Handle Dimension	Material	Base plate	Door thickness range	Spindle size, mm	Type	5074.0800/FS	LN199NX	Refer to drawing	SUS304	TLD236ER-P	35 to 70mm	8*8	unsprung	<b>5559.0800/FS</b>	<b>LN216NX</b>	<b>Refer to drawing</b>	<b>SUS304</b>	<b>TLD236ER-P</b>	<b>35 to 70mm</b>	<b>8*8</b>	<b>unsprung</b>	5557.0800/FS	LN200NX	Refer to drawing	SUS304	TLD236ER-P	35 to 70mm	8*8	unsprung
Model	Lever Handle Drawing#	Lever Handle Dimension	Material	Base plate	Door thickness range	Spindle size, mm	Type																									
5074.0800/FS	LN199NX	Refer to drawing	SUS304	TLD236ER-P	35 to 70mm	8*8	unsprung																									
<b>5559.0800/FS</b>	<b>LN216NX</b>	<b>Refer to drawing</b>	<b>SUS304</b>	<b>TLD236ER-P</b>	<b>35 to 70mm</b>	<b>8*8</b>	<b>unsprung</b>																									
5557.0800/FS	LN200NX	Refer to drawing	SUS304	TLD236ER-P	35 to 70mm	8*8	unsprung																									
<p><b>Schedule of Components:</b></p> <p>See Appendix A –Product Photos and Drawings for component list and raw material information.</p> <p>Detail "Ratings" information listed as following:</p> <p>First digit (Category of use): Grade 3 – high frequency of use by public or others with little incentive to exercise care and with a high chance of misuse, e.g. public office doors;;</p> <p>Second digit (Durability): Grade 7 – medium frequency of use: 200, 000 test cycles;</p> <p>Third digit (Door mass): No classification;</p> <p>Fourth digit (Fire resistance): – Not included in this test report;</p> <p>Fifth digit (Safety): Grade 1 – Safety applications;</p> <p>Sixth digit (Corrosion resistance): Grade 4 – very high resistance;</p> <p>Seventh digit (Security): Grade 0 – no performance determined;</p> <p>Eighth digit (Type of operation): type U – unsprung furniture.</p>																																

EN 1906															
Clause	Requirement – Test	Result - Remark			Verdict										
<b>4</b>	<b>CLASSIFICATION</b>														
4.1	Coding system				—										
4.1.2	Category of use:	3			—										
4.1.3	Durability	7			—										
4.1.4	Door mass	—			—										
4.1.5	Fire resistance	—			—										
4.1.6	Safety	1			—										
4.1.7	Corrosion resistance	4			—										
4.1.8	Security	0			—										
4.1.9	Type of operation	U			—										
<b>5</b>	<b>REQUIREMENTS</b>														
5.1	General Sets of furniture shall be classified in grades 1 to 4 in regard to performance requirements specified in 5.2 to 5.13.	Refer to Clause 5.2 to 5.13			—										
	Materials in products shall not release any dangerous substances in excess of the maximum levels specified in the European material standards.	Informative			—										
5.2	Check of spindle and fastening elements The spindle and fastening elements shall be supplied or specified by the manufacturer with every set of lock or latch furniture. The manufacturer shall state clearly the door thickness or range of the door thicknesses for which the furniture is suitable and in the case of spring assisted and spring loaded furniture, the angle of rotation permitted by the design.	Spindle and fastening elements were supplied by manufacturer.  Range of door thicknesses: 35 mm to 70 mm.			P										
5.3	Rotational torque strength Lock or latch furniture shall show no failure of any component and the lever handles or knobs shall still operate after the test. Lever handles or knobs shall not deform permanently more than 5 mm as measured at 50 mm ± 2mm from the axis of rotation by the dial gauge.  Category of use acceptance criteria: <table border="1" data-bbox="290 1803 890 1877"> <tr> <td>Grade</td> <td>1</td> <td>2</td> <td>3</td> <td>4</td> </tr> <tr> <td>Torque (Nm)</td> <td>20</td> <td>30</td> <td>40</td> <td>50</td> </tr> </table>	Grade	1	2	3	4	Torque (Nm)	20	30	40	50	Rotational torque 40 Nm.  Permanent deformation: 2,9 mm			P
Grade	1	2	3	4											
Torque (Nm)	20	30	40	50											

5.4	<p>Axial strength of lock furniture or latch furniture and fixing</p> <p>There shall be no fail of any component and lever handles or knobs shall still operate after the test. After test the permanent deformation for lever handles or knobs measured at the reference point 75 mm ± 2mm from the axis of rotation shall not increase by more than 2 mm.</p> <p>Category of use acceptance criteria:</p> <table border="1" data-bbox="292 568 890 636"> <tr> <td>Grade</td> <td>1</td> <td>2</td> <td>3</td> <td>4</td> </tr> <tr> <td>Load (N)</td> <td>300</td> <td>500</td> <td>800</td> <td>1000</td> </tr> </table>	Grade	1	2	3	4	Load (N)	300	500	800	1000	<p>Axial load: 800 N.</p> <p>Permanent deformation: 0,6 mm</p>	P
Grade	1	2	3	4									
Load (N)	300	500	800	1000									
5.5	Free play and safety		—										
5.5.1	<p>Requirement of free play</p> <p>The maximum total movement measured shall not exceed the limit as below,</p> <p>Category of use acceptance criteria:</p> <table border="1" data-bbox="292 882 890 949"> <tr> <td>Grade</td> <td>1</td> <td>2</td> <td>3</td> <td>4</td> </tr> <tr> <td>Total movement (mm)</td> <td>≤10</td> <td>≤10</td> <td>≤6</td> <td>≤6</td> </tr> </table> <p>This requirement only applies to lever handles and knobs that will not be driven during the endurance test.</p>	Grade	1	2	3	4	Total movement (mm)	≤10	≤10	≤6	≤6	<p>Maximum movement:</p> <p>0,6 mm</p>	P
Grade	1	2	3	4									
Total movement (mm)	≤10	≤10	≤6	≤6									
5.5.2	<p>Safety requirement</p> <p>When the lock or latch furniture is fitted to the test block there shall be no sharp edges that can cause injury.</p>	No sharp edges can cause injury.	P										
5.6	<p>Free angular movement or misalignment</p> <p>The free angular movement or misalignment shall not exceed the limit as below,</p> <p>Category of use acceptance criteria:</p> <table border="1" data-bbox="292 1431 890 1498"> <tr> <td>Grade</td> <td>1</td> <td>2</td> <td>3</td> <td>4</td> </tr> <tr> <td>Total movement (mm)</td> <td>≤10</td> <td>≤10</td> <td>≤5</td> <td>≤5</td> </tr> </table> <p>This requirement applies to all furniture with either a fixed or floating spindle.</p>	Grade	1	2	3	4	Total movement (mm)	≤10	≤10	≤5	≤5	Maximum movement: 0,5 mm	P
Grade	1	2	3	4									
Total movement (mm)	≤10	≤10	≤5	≤5									
5.7	Torque of return mechanism		—										
5.7.1	General	See item 5.7.2 and 5.7.4	—										

5.7.2	<p>Unsprung and spring-assisted lever handles</p> <p>Category of use acceptance criteria:</p> <p>For unsprung lever handles, maximum moment,</p> <table border="1" data-bbox="292 367 874 472"> <tr> <td>Grade</td> <td>1</td> <td>2</td> <td>3</td> <td>4</td> </tr> <tr> <td>Operate moment (Nm)</td> <td>—</td> <td>—</td> <td>—</td> <td>—</td> </tr> <tr> <td>Return moment (Nm)</td> <td colspan="2">≤0,6</td> <td colspan="2">≤1,5</td> </tr> </table> <p>For spring assisted lever handles,</p> <table border="1" data-bbox="292 533 874 674"> <tr> <td>Grade</td> <td>1</td> <td>2</td> <td>3</td> <td>4</td> </tr> <tr> <td>Operate moment (Nm)</td> <td colspan="2">≤1,5</td> <td colspan="2">≤2,4</td> </tr> <tr> <td>Return moment (Nm)</td> <td colspan="2">≤0,6</td> <td colspan="2">≤1,5</td> </tr> <tr> <td>Angle of rotation</td> <td colspan="4">≥40°</td> </tr> </table>	Grade	1	2	3	4	Operate moment (Nm)	—	—	—	—	Return moment (Nm)	≤0,6		≤1,5		Grade	1	2	3	4	Operate moment (Nm)	≤1,5		≤2,4		Return moment (Nm)	≤0,6		≤1,5		Angle of rotation	≥40°				<p>Unsprung lever handles:</p> <p>Return moment: &lt;0,5 Nm</p>	P
Grade	1	2	3	4																																		
Operate moment (Nm)	—	—	—	—																																		
Return moment (Nm)	≤0,6		≤1,5																																			
Grade	1	2	3	4																																		
Operate moment (Nm)	≤1,5		≤2,4																																			
Return moment (Nm)	≤0,6		≤1,5																																			
Angle of rotation	≥40°																																					
5.7.3	<p>Unsprung knobs</p> <p>Category of use acceptance criteria:</p> <table border="1" data-bbox="292 775 874 880"> <tr> <td>Grade</td> <td>1</td> <td>2</td> <td>3</td> <td>4</td> </tr> <tr> <td>Operate moment (Nm)</td> <td>—</td> <td>—</td> <td>—</td> <td>—</td> </tr> <tr> <td>Return moment (Nm)</td> <td colspan="4">≤0,6</td> </tr> </table>	Grade	1	2	3	4	Operate moment (Nm)	—	—	—	—	Return moment (Nm)	≤0,6				Unsprung lever handles	N/A																				
Grade	1	2	3	4																																		
Operate moment (Nm)	—	—	—	—																																		
Return moment (Nm)	≤0,6																																					
5.7.4	<p>Spring-loaded lever handles or knobs</p> <p>The torque required to rotate the lever handles or knobs through a maximum of 60° 0/+5° or through the angle of rotation possible by the design shall meet the specified requirement as below,</p> <p>Category of use acceptance criteria:</p> <table border="1" data-bbox="292 1149 890 1317"> <tr> <td>Grade</td> <td>1</td> <td>2</td> <td>3</td> <td>4</td> </tr> <tr> <td>Operate moment (Nm)</td> <td colspan="2">≤1,5</td> <td colspan="2">≤2,4</td> </tr> <tr> <td>Return moment (Nm)</td> <td>—</td> <td>—</td> <td>—</td> <td>—</td> </tr> <tr> <td>Limited deviations "at rest"</td> <td>±4°</td> <td>±2°</td> <td>±1°</td> <td>±1°</td> </tr> </table>	Grade	1	2	3	4	Operate moment (Nm)	≤1,5		≤2,4		Return moment (Nm)	—	—	—	—	Limited deviations "at rest"	±4°	±2°	±1°	±1°	Unsprung lever handles	N/A															
Grade	1	2	3	4																																		
Operate moment (Nm)	≤1,5		≤2,4																																			
Return moment (Nm)	—	—	—	—																																		
Limited deviations "at rest"	±4°	±2°	±1°	±1°																																		
5.8	<p>Durability of mechanism</p> <p>There shall be no failure of any component and the lever handle or knob shall still operate after test.</p> <p>After the test, the "at-rest" position of spring-loaded door furniture when against its stops shall conform to the "at-rest" position recorded before commencing, the detailed requirement specified as below,</p> <table border="1" data-bbox="292 1682 890 1906"> <tr> <td>Grade</td> <td>1</td> <td>2</td> <td>3</td> <td>4</td> </tr> <tr> <td>Number of cycles</td> <td colspan="2">100k</td> <td colspan="2">200k</td> </tr> <tr> <td>force L (N)</td> <td colspan="2">60</td> <td colspan="2">100</td> </tr> <tr> <td>force P (N)</td> <td colspan="2">60</td> <td colspan="2">100</td> </tr> <tr> <td>Limited deviations "at rest" (except for spring assisted levers)</td> <td>±4°</td> <td>±2°</td> <td>±1°</td> <td>±1°</td> </tr> </table>	Grade	1	2	3	4	Number of cycles	100k		200k		force L (N)	60		100		force P (N)	60		100		Limited deviations "at rest" (except for spring assisted levers)	±4°	±2°	±1°	±1°	200 000 cycles, function correctly after test;	P										
Grade	1	2	3	4																																		
Number of cycles	100k		200k																																			
force L (N)	60		100																																			
force P (N)	60		100																																			
Limited deviations "at rest" (except for spring assisted levers)	±4°	±2°	±1°	±1°																																		

5.9	Repeat test of axial strength of lock or latch furniture and methods of fixing The lock or latch furniture shall meet the requirement of 5.4.	Axial load: 800 N. Permanent deformation: 0,6 mm	P										
5.10	Repeat test of free play measurement The lock or latch furniture shall meet the requirement of 5.5.1	Maximum movement: 0,8 mm	P										
5.11	Repeat test of measurement of free angular movement or misalignment The lock or latch furniture shall meet the requirement of 5.6.	Maximum movement: 0,7 mm	P										
5.12	Repeat test or torque of return mechanism The lock or latch furniture shall meet the requirement of 5.7.	Unsprung lever handles: Return moment: <0,5 Nm	P										
5.13	Axial strength for safety furniture (optional) Category of use acceptance criteria: <table border="1" data-bbox="292 947 874 1014"> <tr> <td>Grade</td> <td>1</td> <td>2</td> <td>3</td> <td>4</td> </tr> <tr> <td>Axial load (N)</td> <td colspan="2">1500</td> <td colspan="2">2500</td> </tr> </table> After test, there shall be no failure of any component and the furniture shall remain fixed to the test block. The lever handle or knob need not operate after completion of the test.	Grade	1	2	3	4	Axial load (N)	1500		2500		Safety application: 2500 N. Remain fixed to the test block	P
Grade	1	2	3	4									
Axial load (N)	1500		2500										
5.14	Corrosion resistance Corrosion resistance shall comply with requirements of EN 1670:1998.	After 240 hours exposure, no visible corrosion was found on the surface which are visible when fitted in service Grade 4. *the fasteners was not evaluated.	P										
<b>8</b>	<b>MARKING</b>		—										
<b>Annex A</b>	<b>Requirements for security lock furniture for use on burglary resistant doors</b>	Furniture not approved for use on burglary resistant doors	N/A										
<b>Annex C</b>	<b>Requirements for lock and latch furniture for use on fire/smoke door assemblies</b>	Not approved for use on fire/smoke door assemblies	N/A										

Appendix A

Product Photos and Drawings

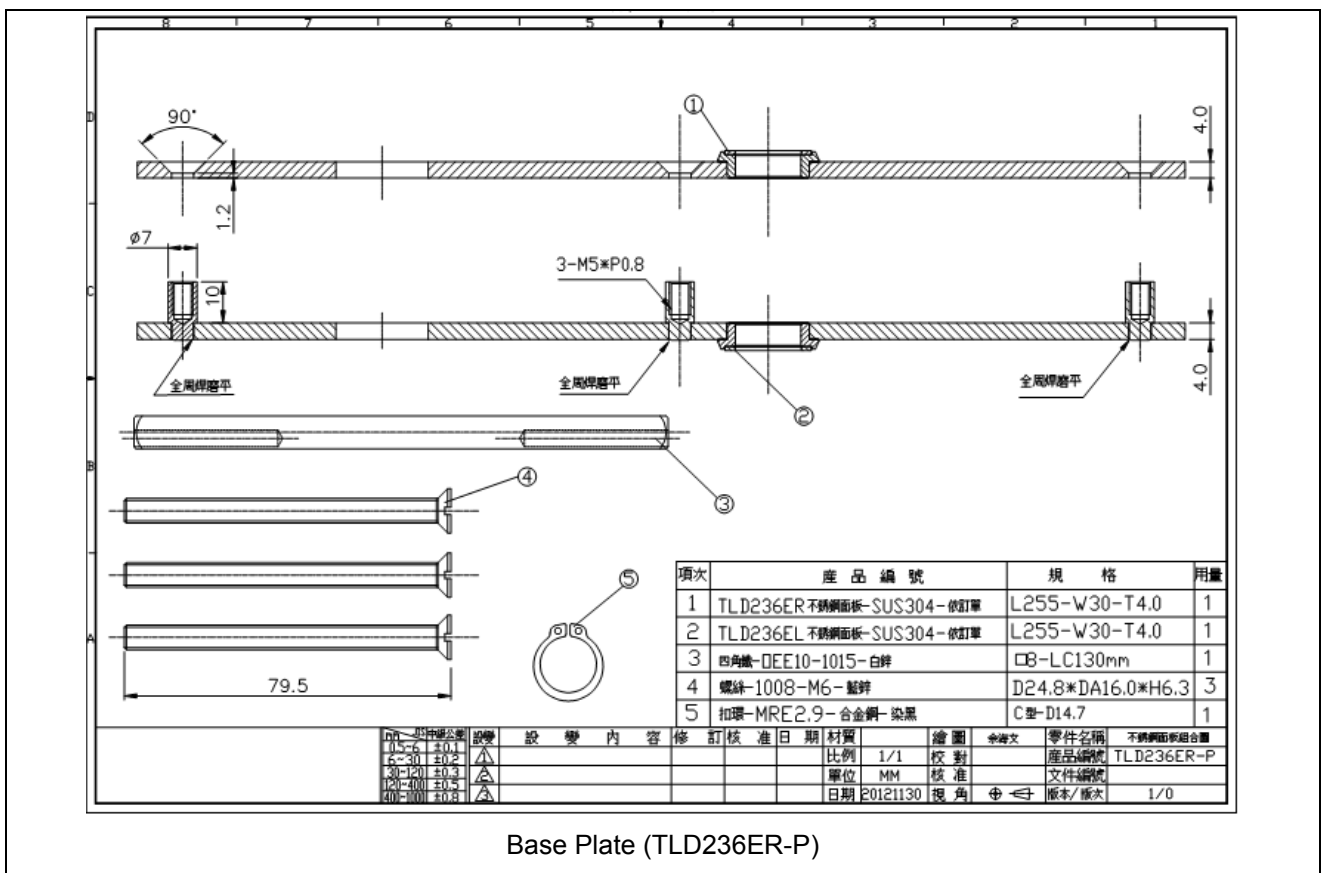
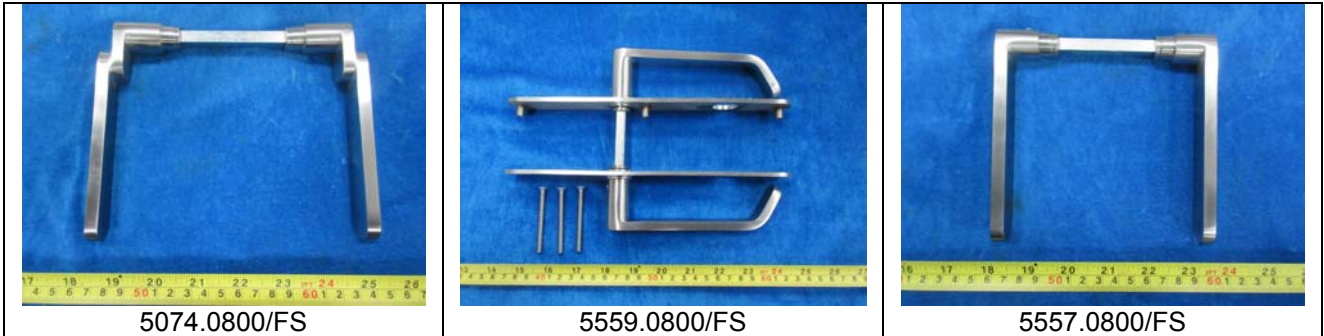

Base Plate (TLD236ER-P)

不可依據圖面量測尺寸

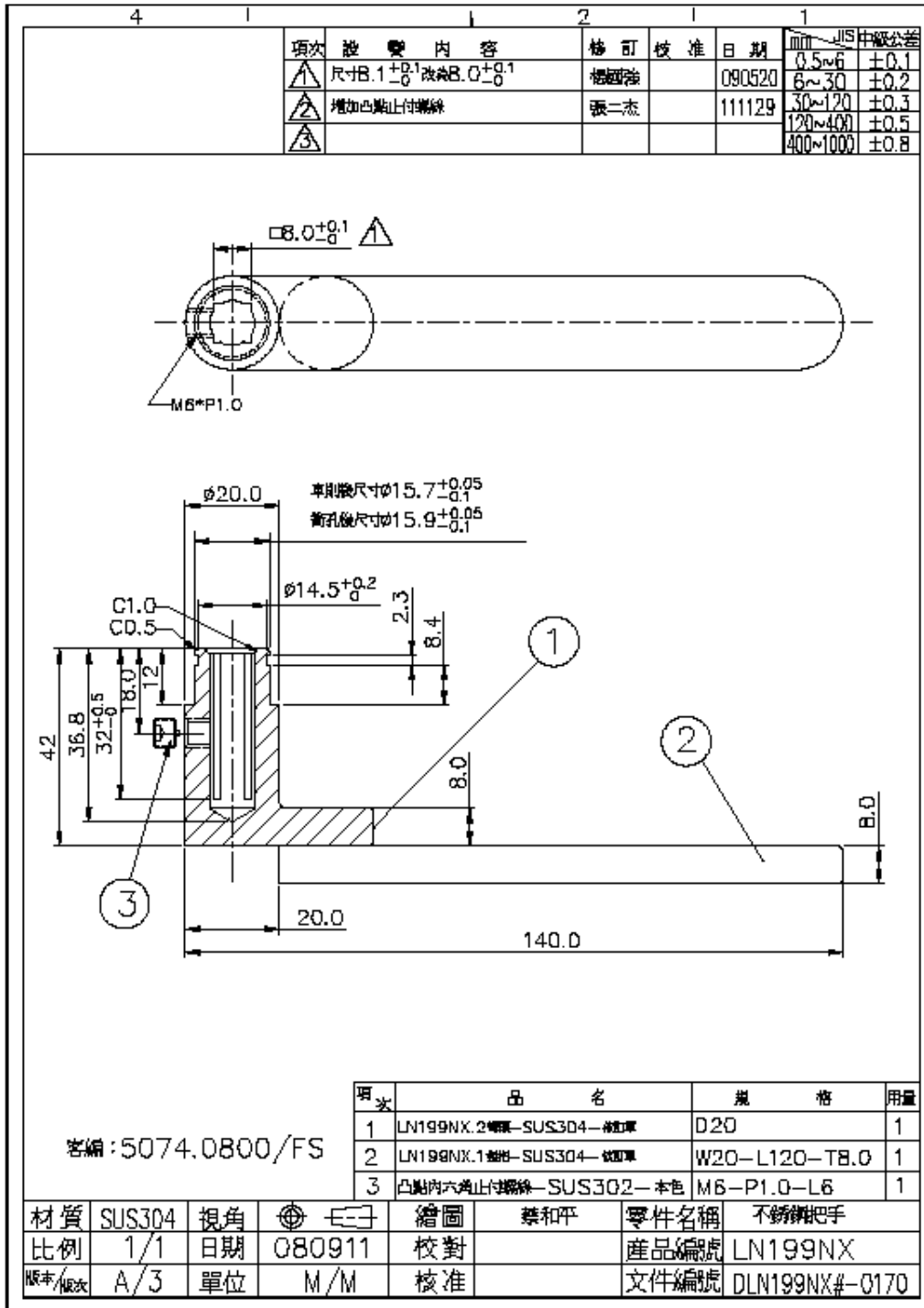

5074.0800/FS



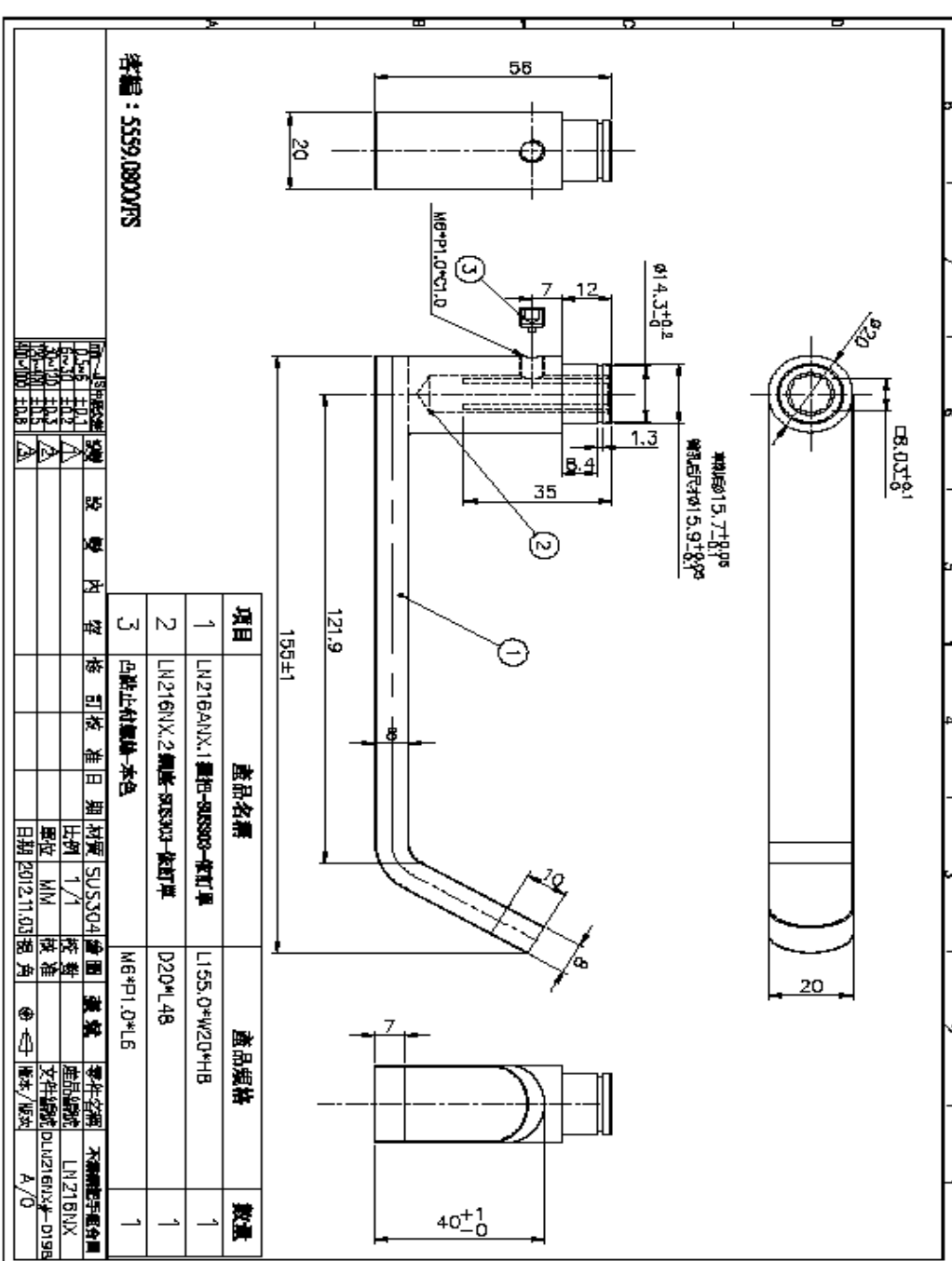

5559.0800/FS

不可依據圖面量測尺寸

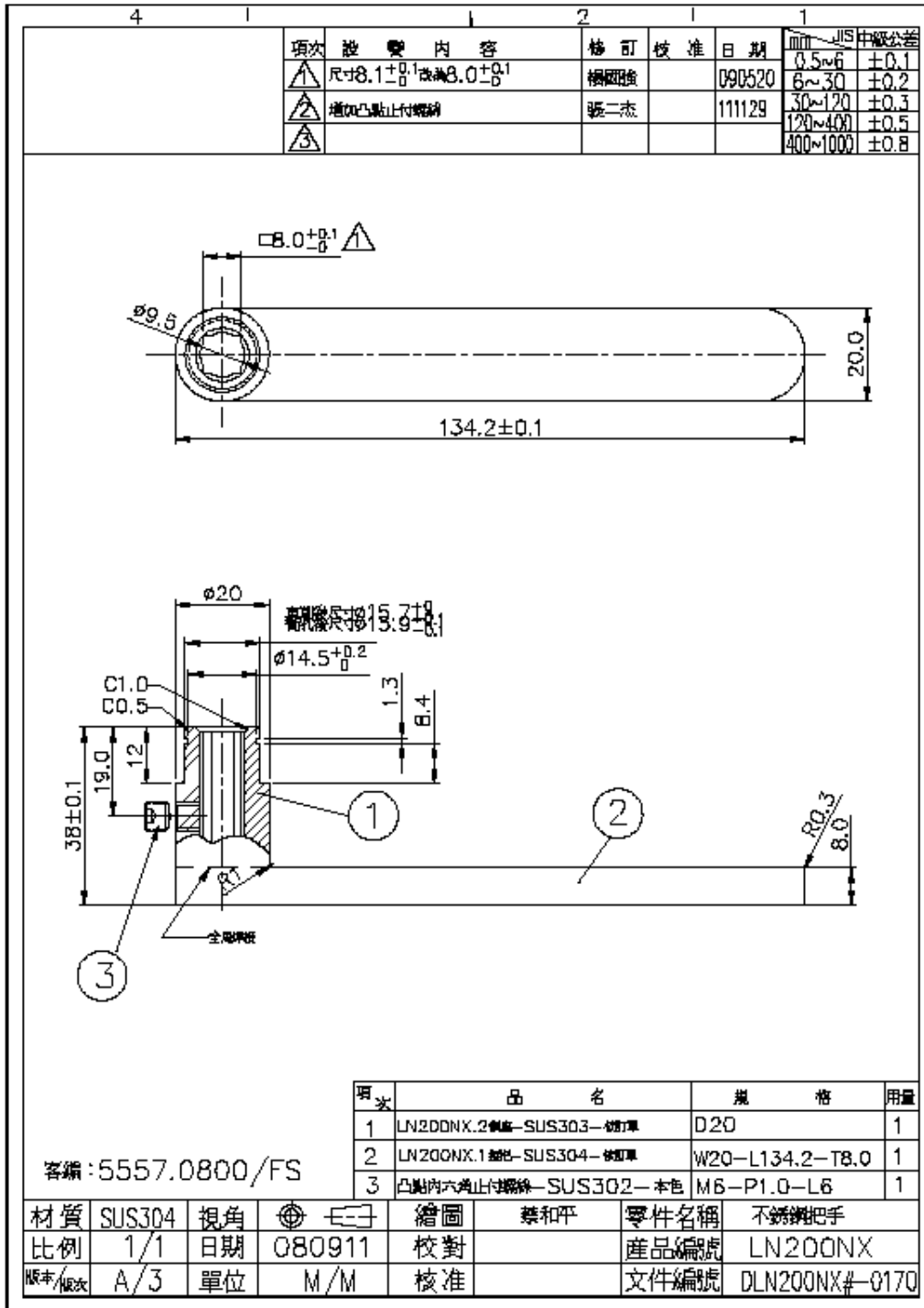

5557.0800/FS

\*\*\*\*\*End of Page\*\*\*\*\*

## Revision Page

---

Revision No.	Date	Changes	Author	Reviewer
0	July 20, 2016	First issue	Credy Chen	Blusea Dong

\*\*\*\*\*End of report\*\*\*\*\*