

The Drawing and its contents are to be kept secret from third parties, particularly competitors. The drawing and documents which go with it are not to be duplicated either in local or extract, or used in other documentation without express approval (815 and 38 UrHG - §1 and 18 UWG). A reservation of rights in accordance with §12 PatG is declared for the event that a patent is granted.

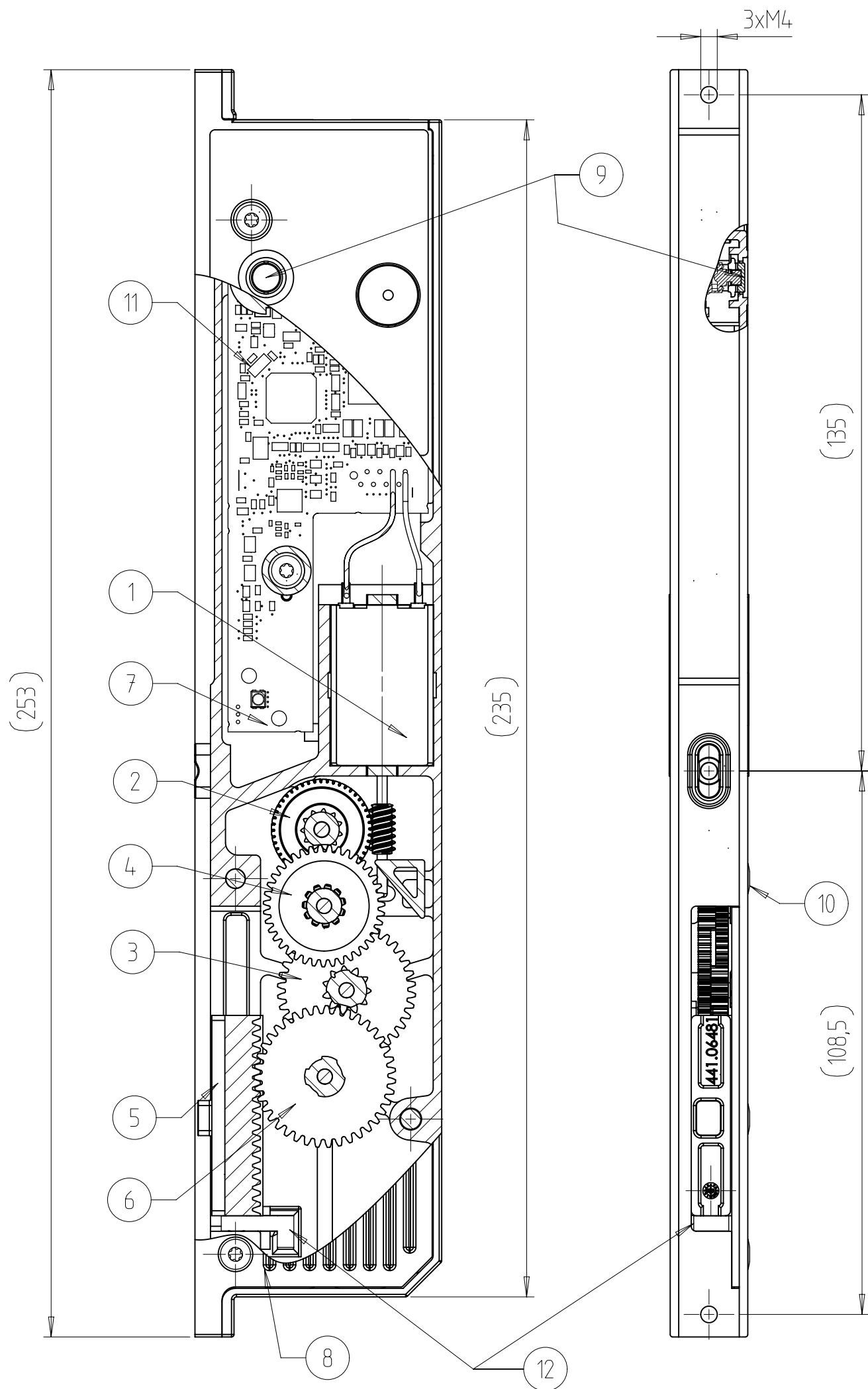

Tolerierung nach ISO 8015

Pos	Benennung	Stck	PDM-Nr.	Teil	Bemerk
12	Daempfer	1	9.709.21225	000	
11	Leiterpla. A-Oeffner 2.1/2.2	1	9.402.20938	000	
10	Torx - Schraube M4x10	5	9.741.14821	000	
9	Druckelement	1	9.498.19254	000	
8	Decke	1	9.020.06483	000	
7	Gehaeuse	1	9.410.06482	000	
6	Zahnrad	1	9.440.06447	000	
5	Zahnstange	1	9.441.06481	000	
4	Zahnrad kplt.	1	7.440.06457	000	
3	Zahnrad kplt.	1	7.440.06456	000	
2	Schneckenrad kplt.	1	7.440.06462	000	
1	Mikromotor	1	WFK-180W-15195	000	

Qty.	Type of Modification	Anpassung fuer A-Oeffner 2.1/2 durchgefuehrt		ANT	Drawn	Approved	Date
				Y6269A	GulA	Knipp0	07.11.2017
Volume /mm³	Weight/g	Material-No.	Item-No.	Tool-No.			
	533,000		F1060/CA UND F1060CF				
		Tolerance	Part-Description				
		ISO2768MK	A-Oeffner 2.1				
Scale		Additional Notice					
1 : 1							
Drawn	RAISIGA	KFV		Document No.	Doc. Part No.	Revision	Status
Date	29.03.2012			3.1050.0007	000	01	20
Appr.				Replacement for :	Test procedure		Size
Date				Replaced by :			A3