

1:1

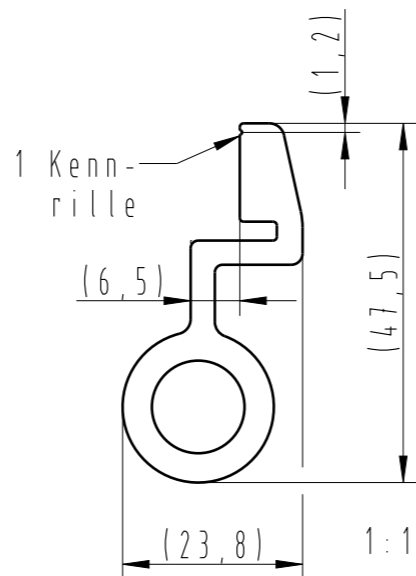

R700Q0005

Neutrale Herstellerkennung nach Absprache		Zul. Abweichung für Maße ohne Toleranzangabe nach ISO 2768-mH		Oberflächen EN ISO 1302 Kanten ISO 13715		Maßstab: 2:1		Gewicht 53,263 g	
Für diese technischen Unterlagen behalten wir uns alle Rechte nach DIN ISO 16016 vor						Werkstoff, Halbzeug EN-AW-6060-T66			
						Rohteil-Nr. R700P0000			
						Model-oder Gesenk-Nr.			
		Datum		Name		Benennung:		Freigegeben	
		Bear. 13.03.2023		KUDLA		RBT AT			
		Gepr.				6,5 / 14,8			
		Norm				Zeichnungsnummer:		Blatt	
		DIS: 121203,ZDR,DRW,00				R700F0024		1	
						Dr. Hahn® TÜRBÄNDER. MADE IN GERMANY.		1	
In.	Änderung	Datum	Name	Urspr.	Ers. f.	Modell-Nr. R700F0024			

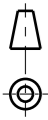

PART