

ASSEM

Für diese technischen Unterlagen behalten wir uns alle Rechte nach DIN ISO 16016 vor				Maßstab: 1:1		Gewicht: g	
				Maße ohne Toleranzangabe nur zur Information			
				Benennung:		NICHT Freigegeben!	
				Datum	Name	Rollenband AT	
				Bear.	13.03.2023	KUDLA	Gutmann
				Gepr.	13.03.2023	KORP	
				Norm			
				DIS:	121205,ZDR,DRW,00		
				Dr. Hahn [®]		Zeichnungsnummer:	
				TÜRBÄNDER. MADE IN GERMANY.		R751_TS01_GEN	
In.	Änderung	Datum	Name	Urspr.:	Ers.f.	Modell-Nr. R751_TS01_GEN	
						Blatt	
						1	
						7	

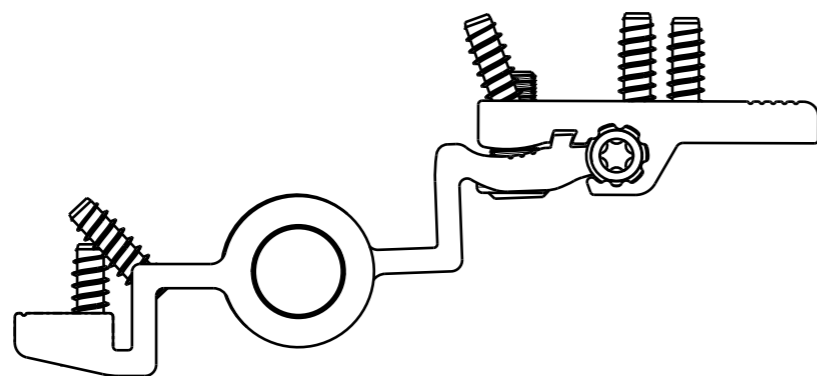

Pos	Menge	Benennung	Sachnummer
1	2	RBT AT 6,5 / 14,8	R700F0024
2	2	Lagerbuchse FBT exzentrisch schwarz	R600K0001
3	1	FBT Einheit komplett Rollenband AT Gutmann	R700B0011
4	1	Lagerbolzen	R600E0007
5	2	Gewindestift M6x5-TX15 A4 oder A2	R400E0010
6	12	Bef.-Schraube RB-AT 4,8x16	R700E0000

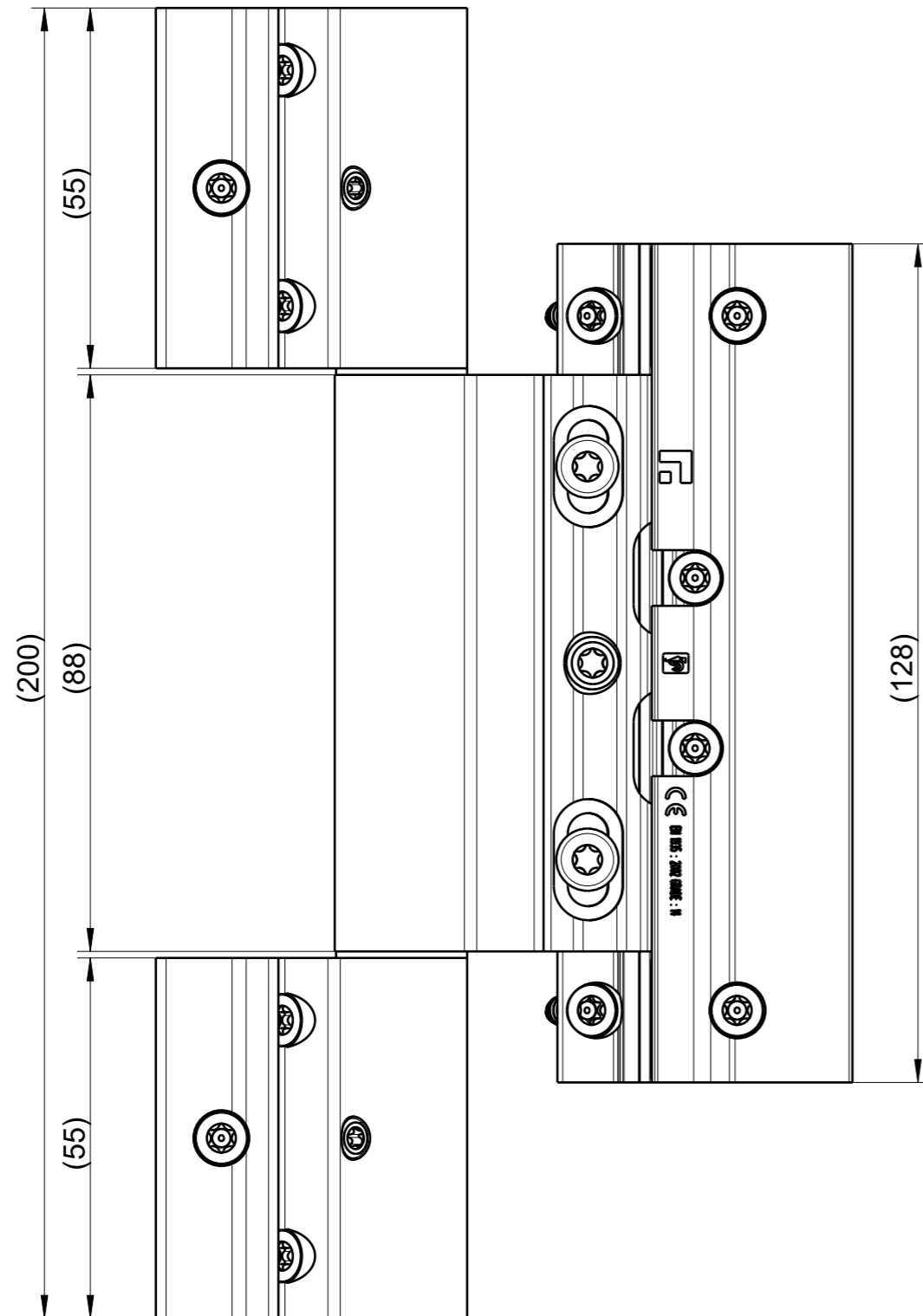
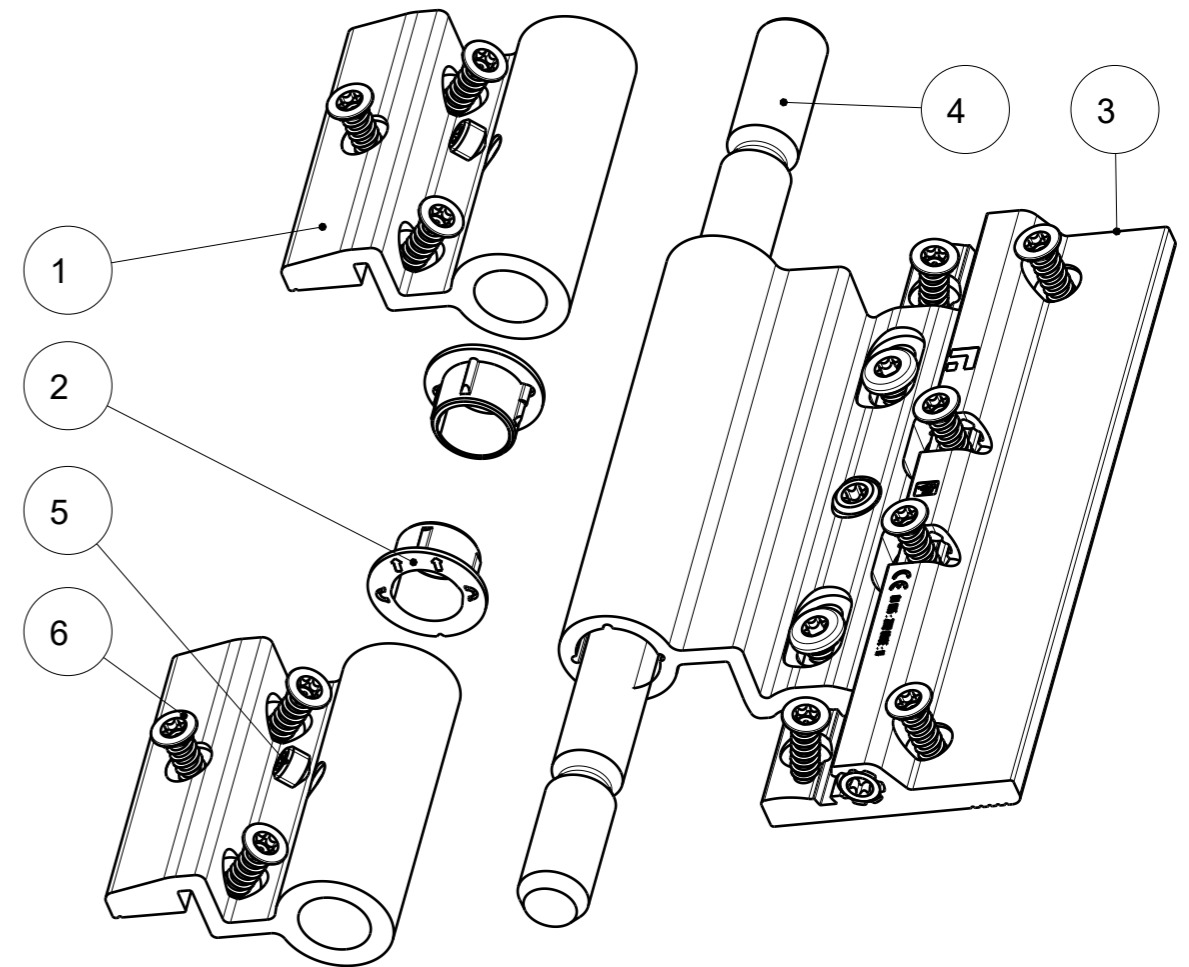

Für diese technischen Unterlagen behalten wir uns alle Rechte nach DIN ISO 16016 vor		Maßstab: 1:1		Gewicht: g	
		Maße ohne Toleranzangabe nur zur Information		Benennung: NICHT Freigegeben!	
		Datum	Name	Rollenband AT Gutmann	
		Bear. 13.03.2023	KUDLA	Zeichnungsnummer: R751_TS01_GEN	
		Gepr. 13.03.2023	KORP	Blatt 2	
		Norm		Blatt 7	
		DIS: 121205,ZDR,DRW,00		Ers.f. Modell-Nr. R751_TS01_GEN	
		Dr. Hahn TÜRBÄNDER. MADE IN GERMANY.			
In.	Änderung	Datum	Name	Urspr.:	

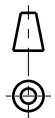

ASSEM

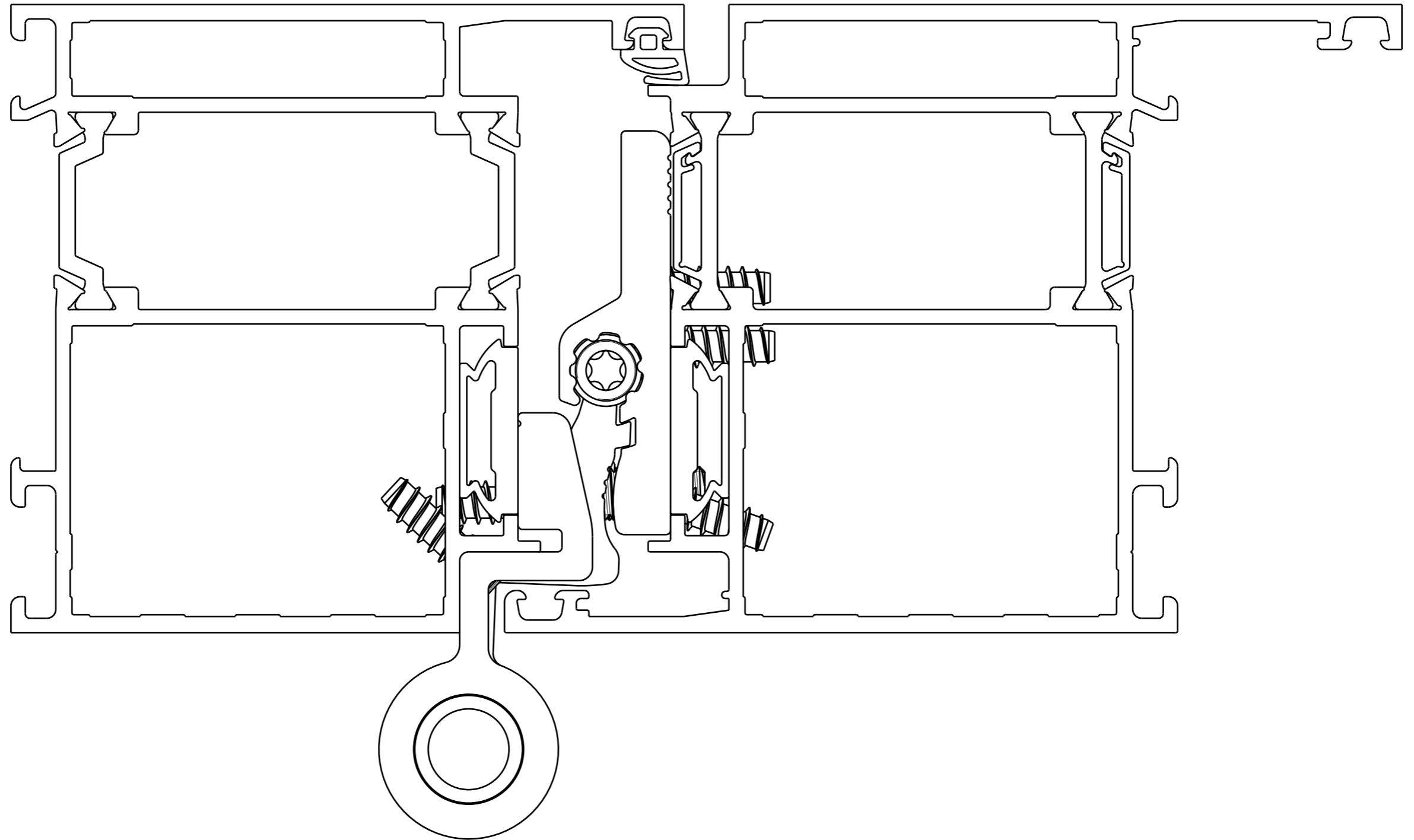

ASSEM

Für diese technischen Unterlagen behalten wir uns alle Rechte nach DIN ISO 16016 vor				Maßstab: 2:1		Gewicht: g			
				Maße ohne Toleranzangabe nur zur Information					
				Benennung:		NICHT Freigegeben!			
				Datum	Name		Rollenband AT Gutmann		
				Bear.	13.03.2023	KUDLA			
				Gepr.	13.03.2023	KORP			
				Norm					
				DIS:	121205,ZDR,DRW,00		Zeichnungsnummer:		
				 Dr. Hahn [®] TÜRBÄNDER. MADE IN GERMANY.		R751_TS01_GEN			
						Blatt			
In.	Änderung	Datum	Name	Urspr.:	Ers.f.	Modell-Nr. R751_TS01_GEN			

3
7

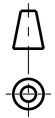
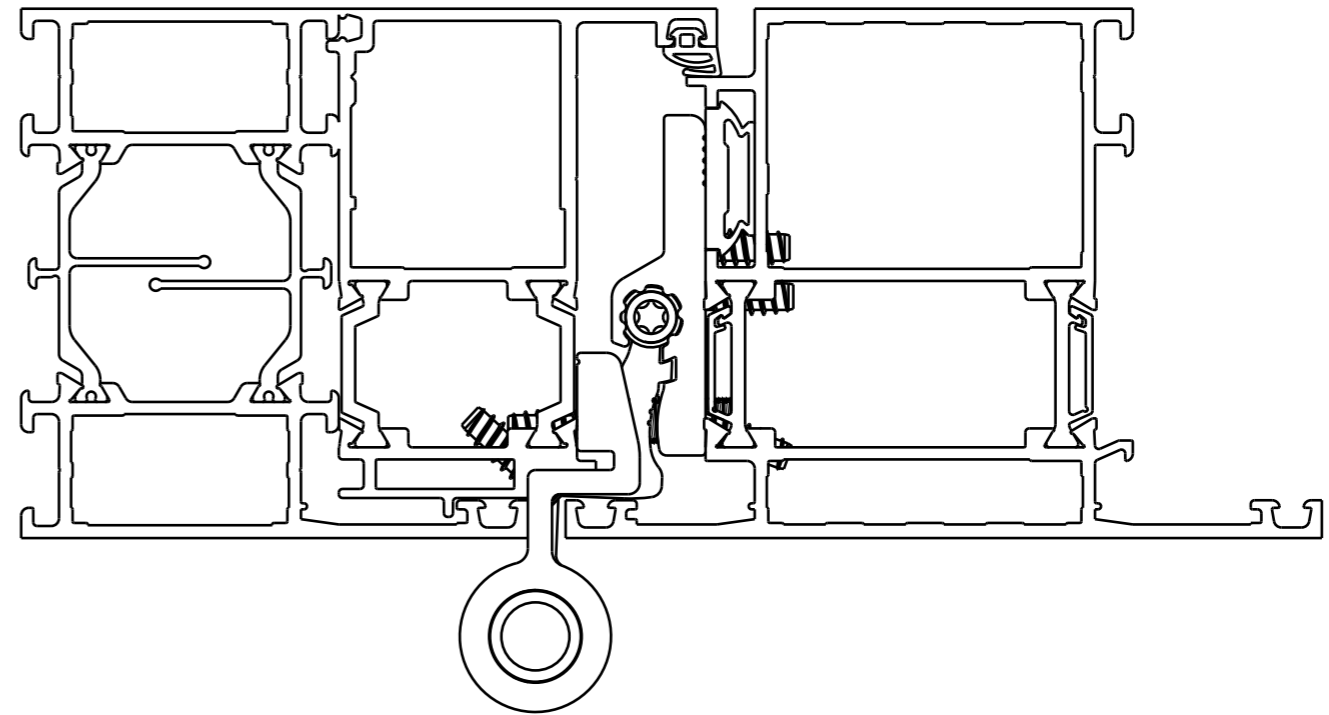
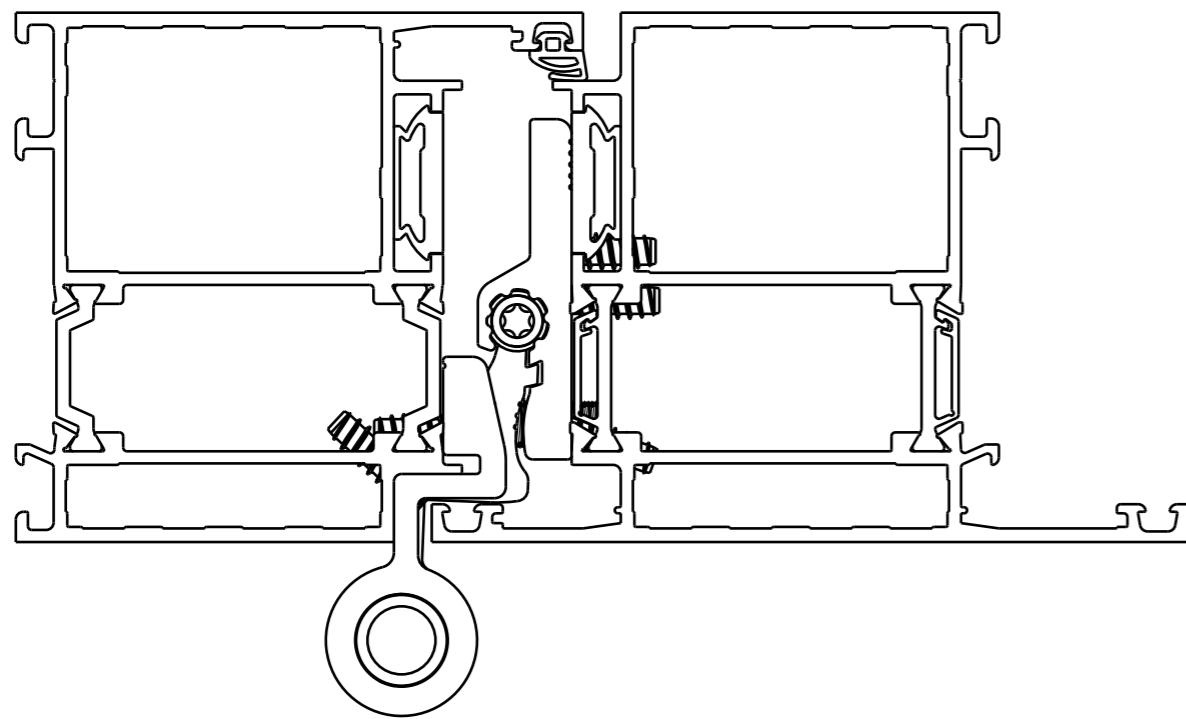
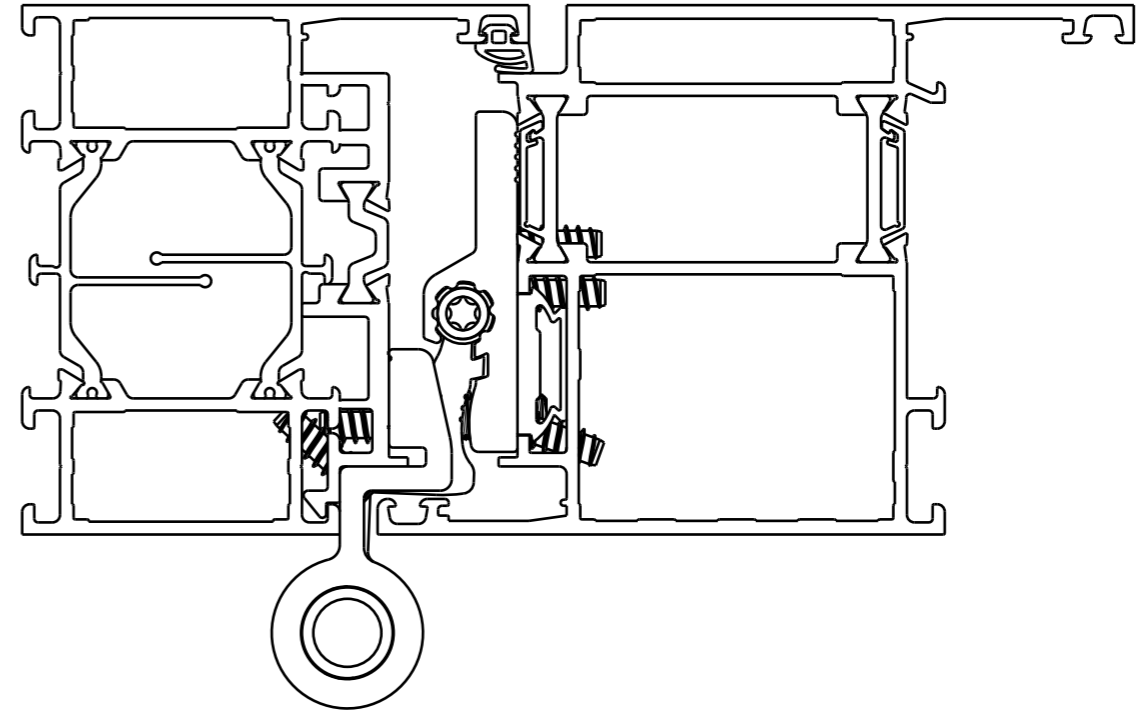
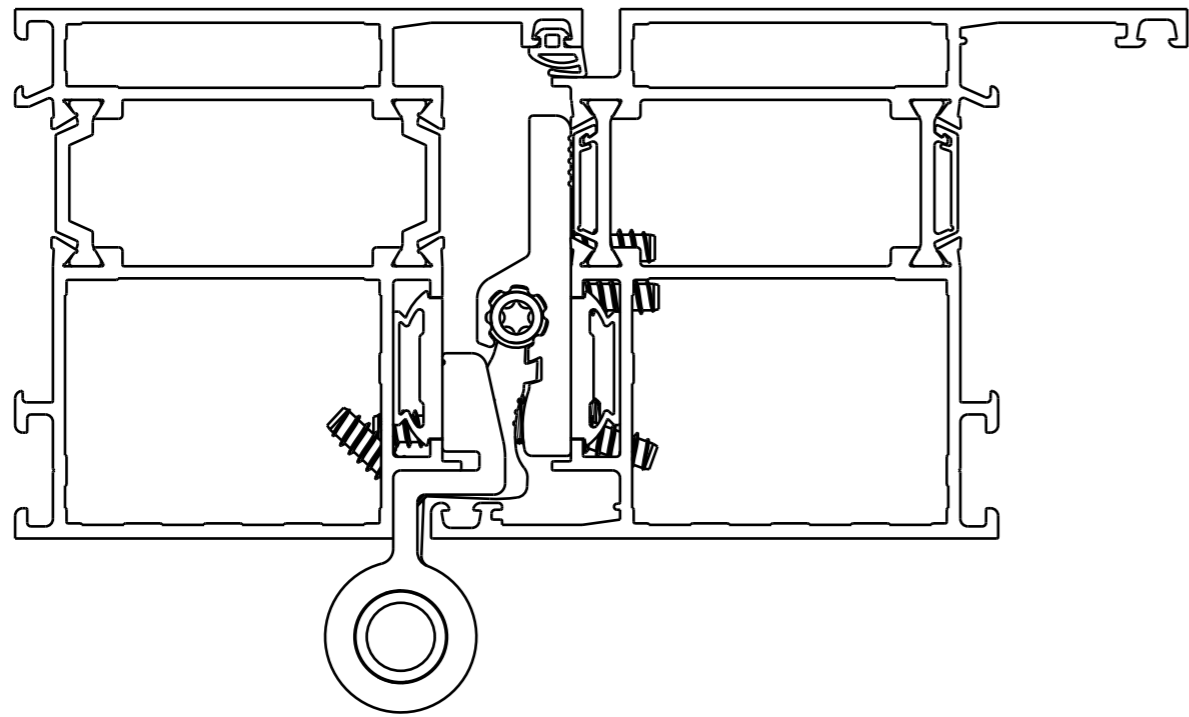

ASSEM

Für diese technischen Unterlagen behalten wir uns alle Rechte nach DIN ISO 16016 vor				Maßstab: 1:1		Gewicht: g		
				Maße ohne Toleranzangabe nur zur Information				
				Benennung:		NICHT Freigegeben!		
				Bear.	13.03.2023	KUDLA		
				Gepr.	13.03.2023	KORP		
				Norm				
				DIS:	121205,ZDR,DRW,00			
				 Dr. Hahn [®] TÜRBÄNDER. MADE IN GERMANY.		Zeichnungsnummer:		Blatt
						R751_TS01_GEN		4
In.	Änderung	Datum	Name	Urspr.:	Ers.f.		Modell-Nr. R751_TS01_GEN	
						7		

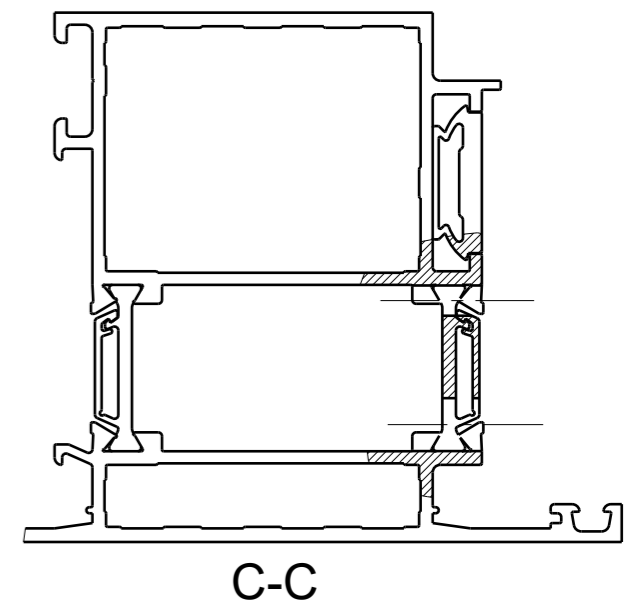
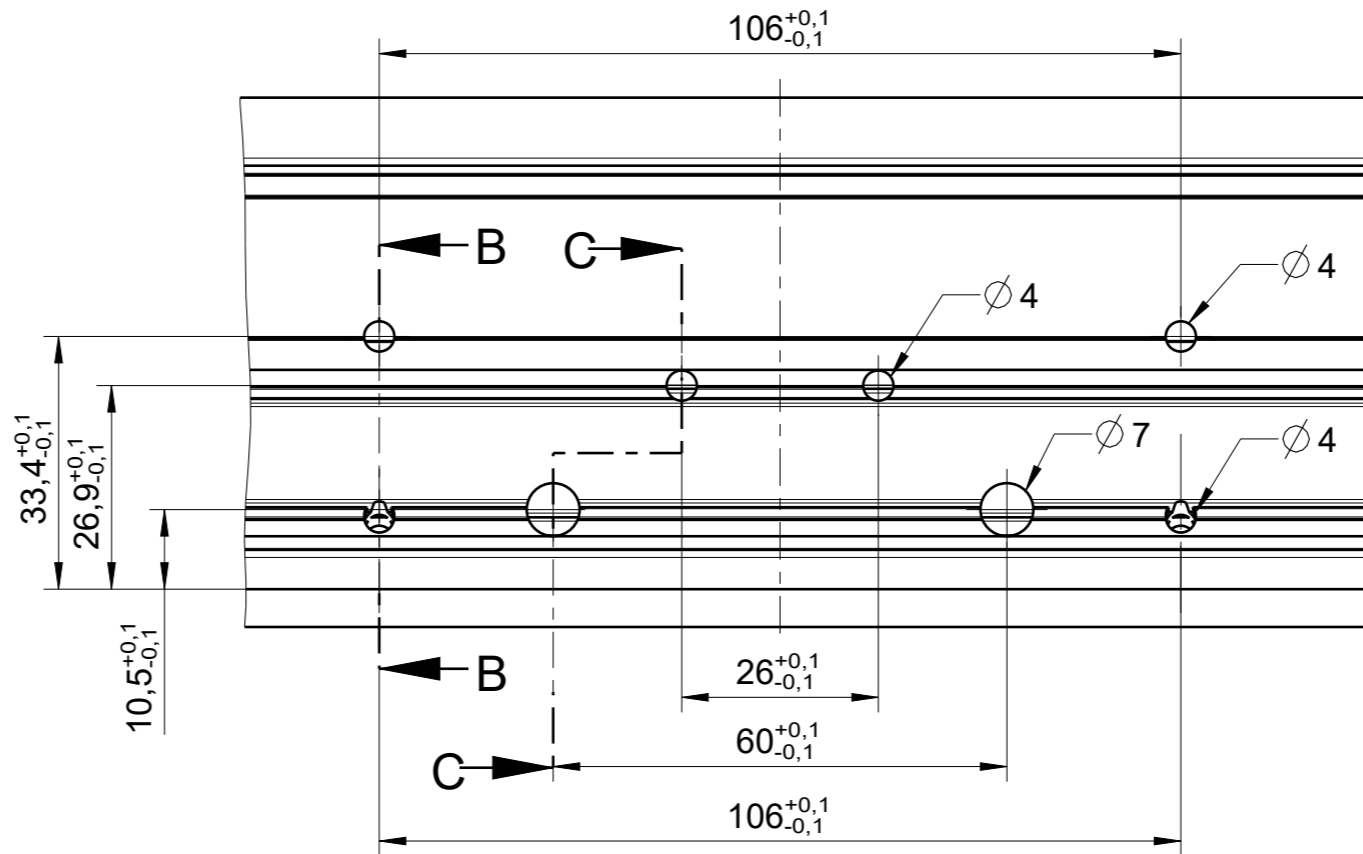
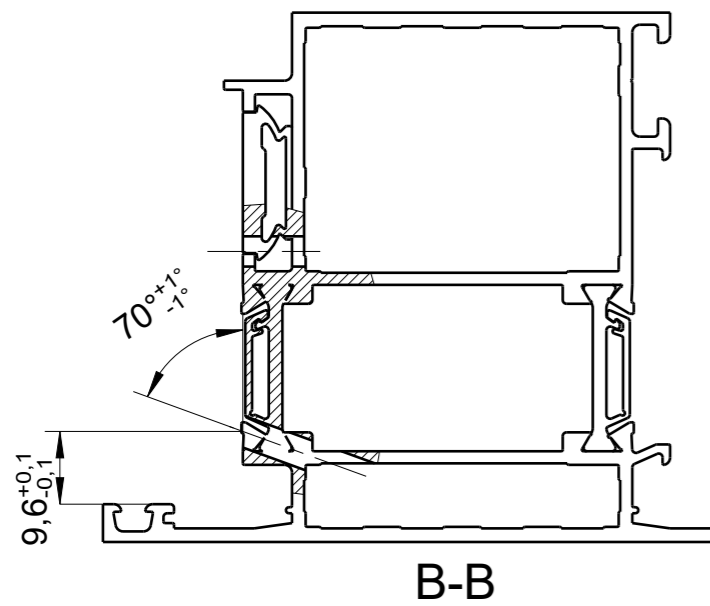
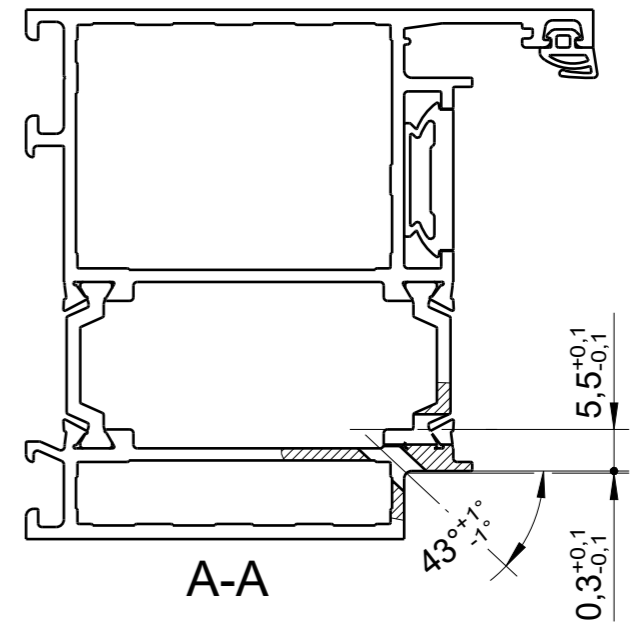
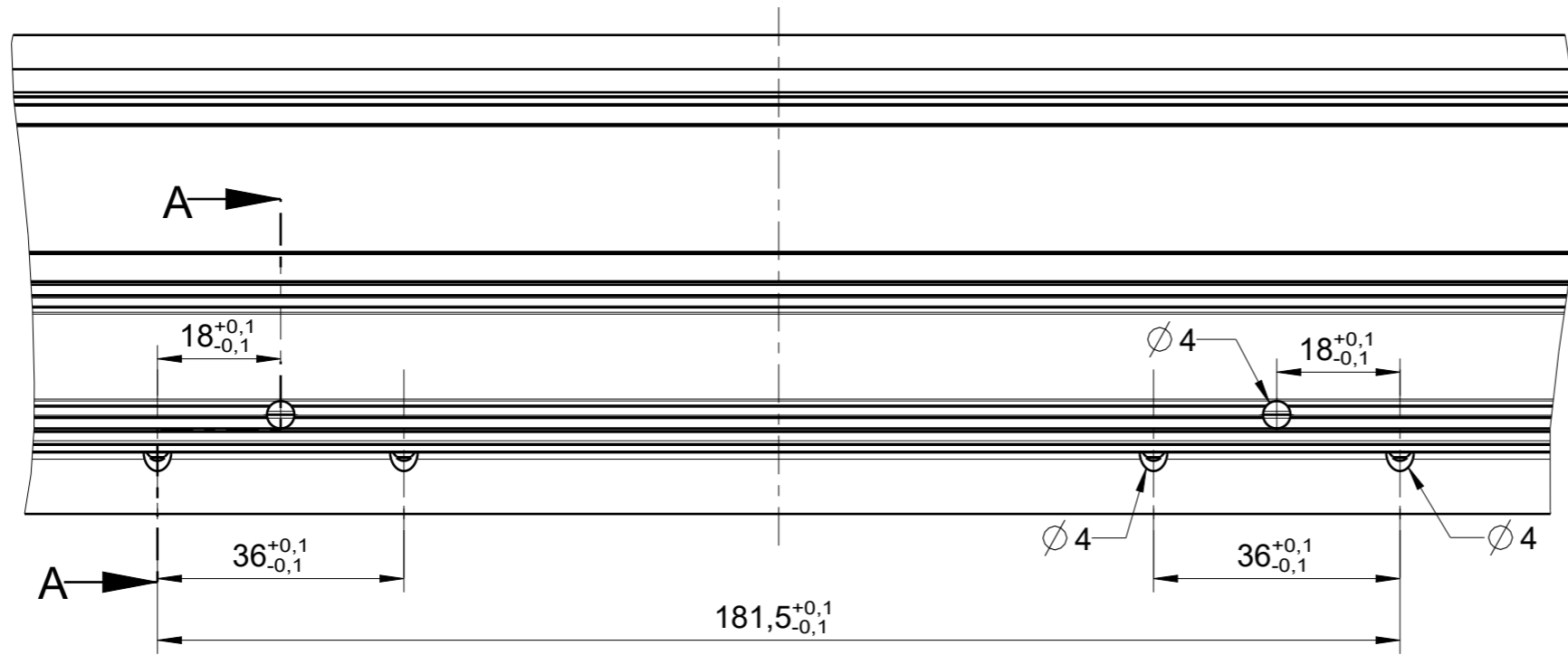

Für diese technischen Unterlagen behalten wir uns alle Rechte nach DIN ISO 16016 vor				Maßstab: 1:1		Gewicht: g	
				Maße ohne Toleranzangabe nur zur Information			
				Benennung:		NICHT Freigegeben!	
				Bear.	13.03.2023	KUDLA	
				Gepr.	13.03.2023	KORP	
				Norm			
				DIS:	121205,ZDR,DRW,00		
				Dr. Hahn [®]		Zeichnungsnummer:	
				TÜRBÄNDER. MADE IN GERMANY.		R751_TS01_GEN	
In.	Änderung	Datum	Name	Urspr.:	Ers.f.	Modell-Nr. R751_TS01_GEN	
						Blatt	5
						Blatt	7

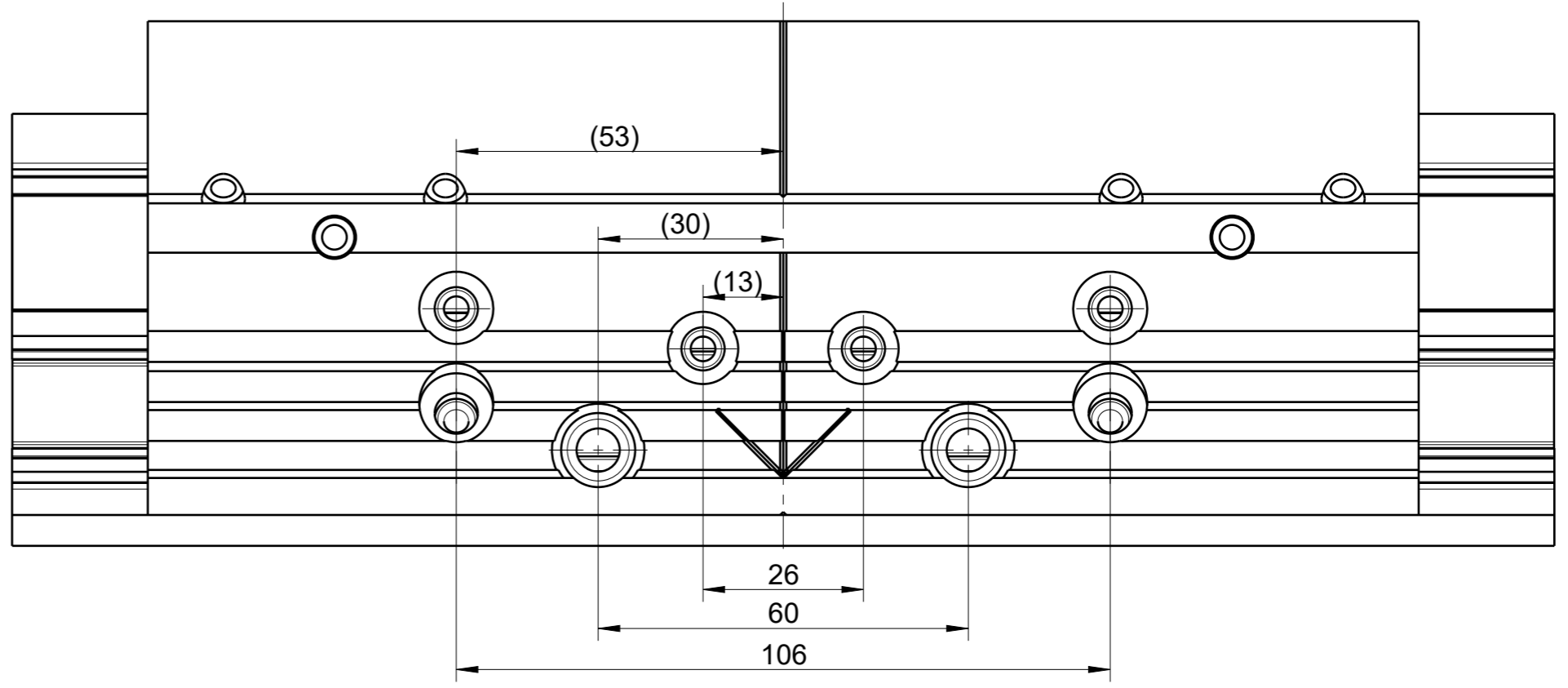
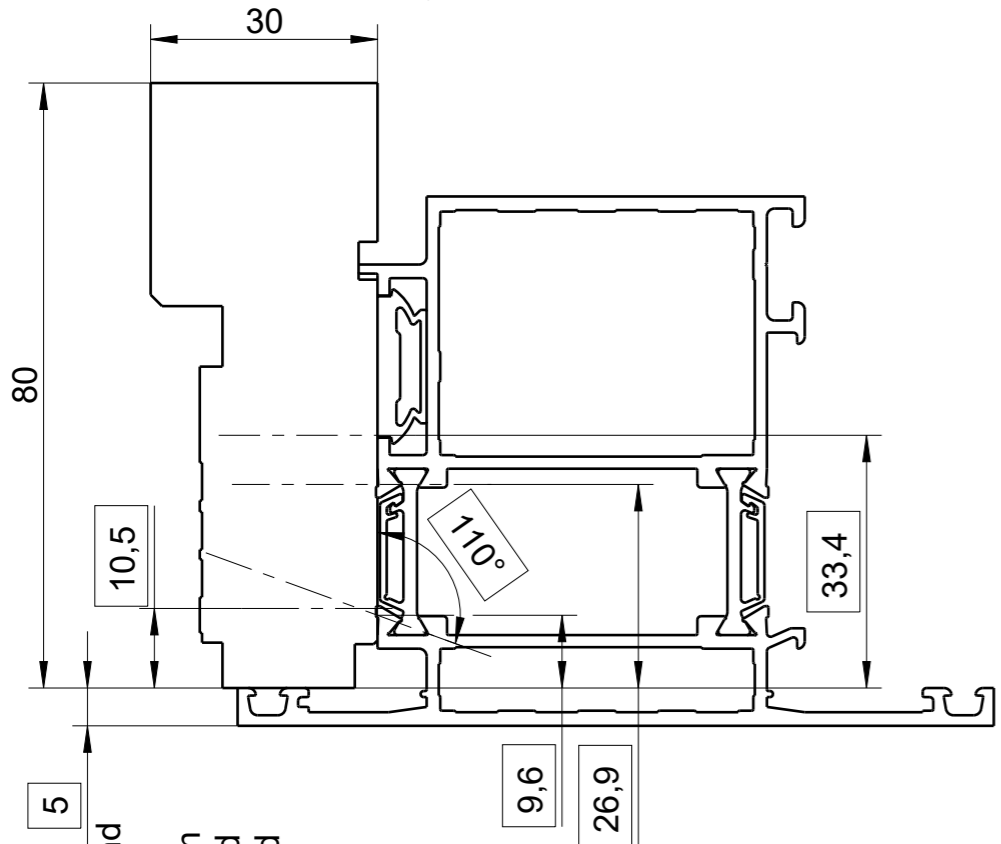
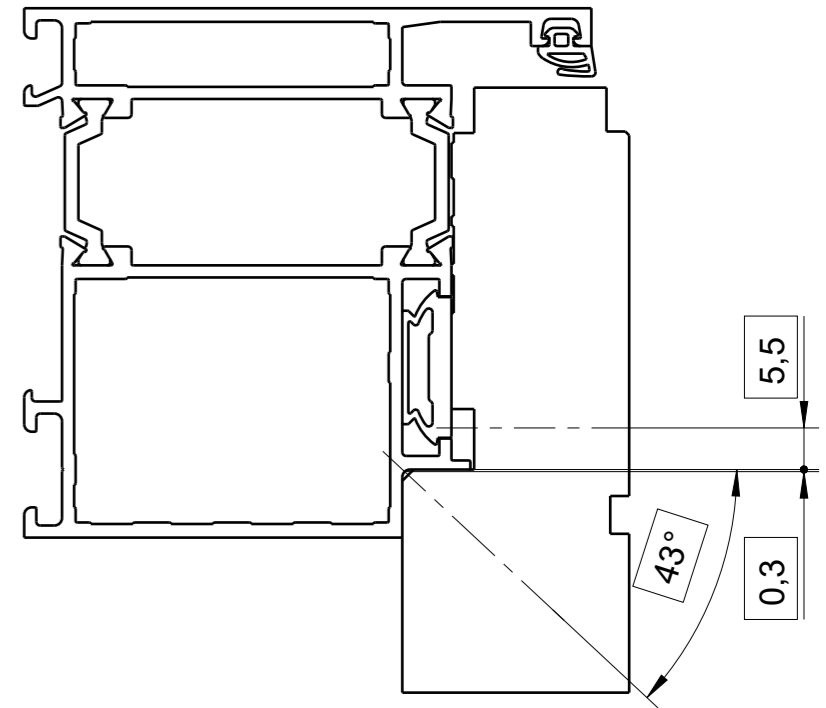
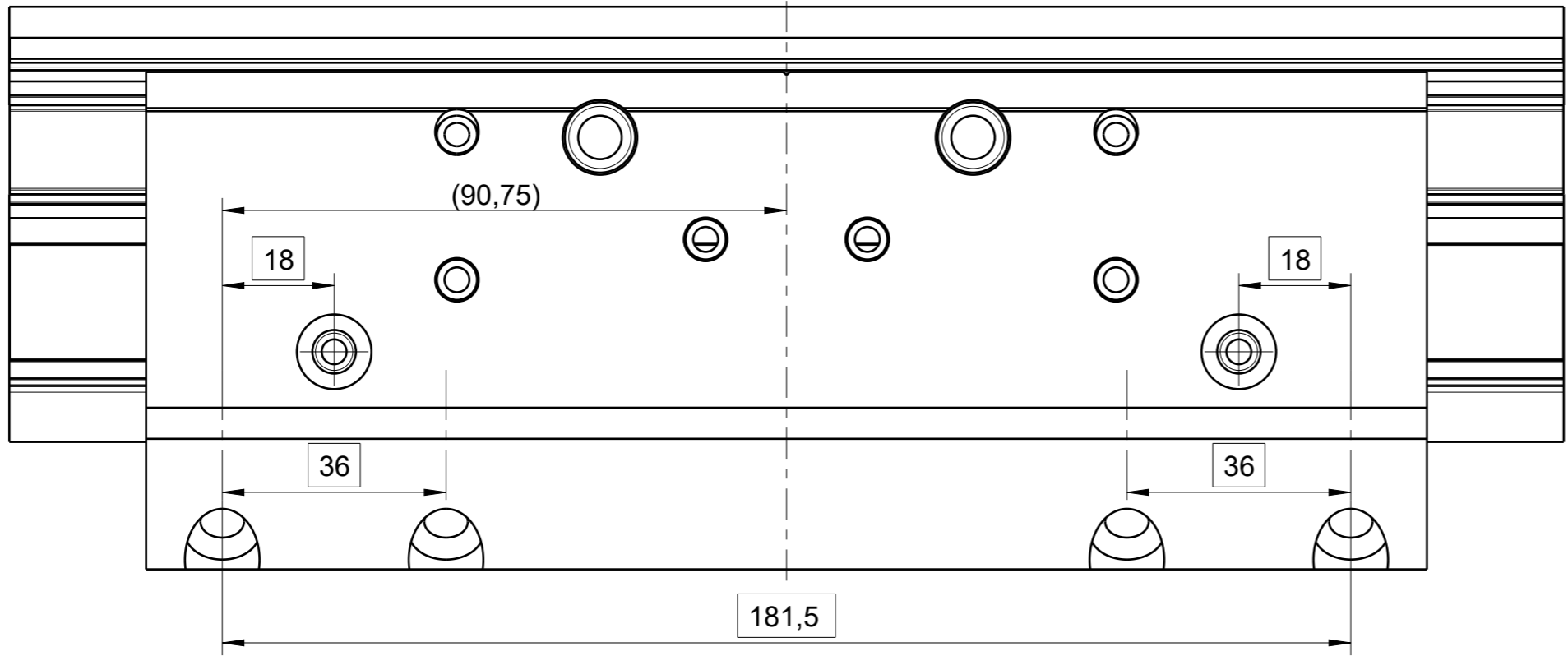

5mm alter Stand
 nicht mehr aktuell
 zukünftig 4,7 mm
 0,3mm Bohrbild
 dichtungsbelastend

Für diese technischen Unterlagen behalten wir uns alle Rechte nach DIN ISO 16016 vor				Maßstab: 1:1		Gewicht: g	
				Maße ohne Toleranzangabe nur zur Information			
				Benennung:		NICHT Freigegeben!	
				Rollenband AT			
				Gutmann			
				Zeichnungsnummer:		Blatt	
				R751_TS01_GEN		6	
						7	
In.	Änderung	Datum	Name	Urspr.:	Ers.f.	Modell-Nr. R751_TS01_GEN	



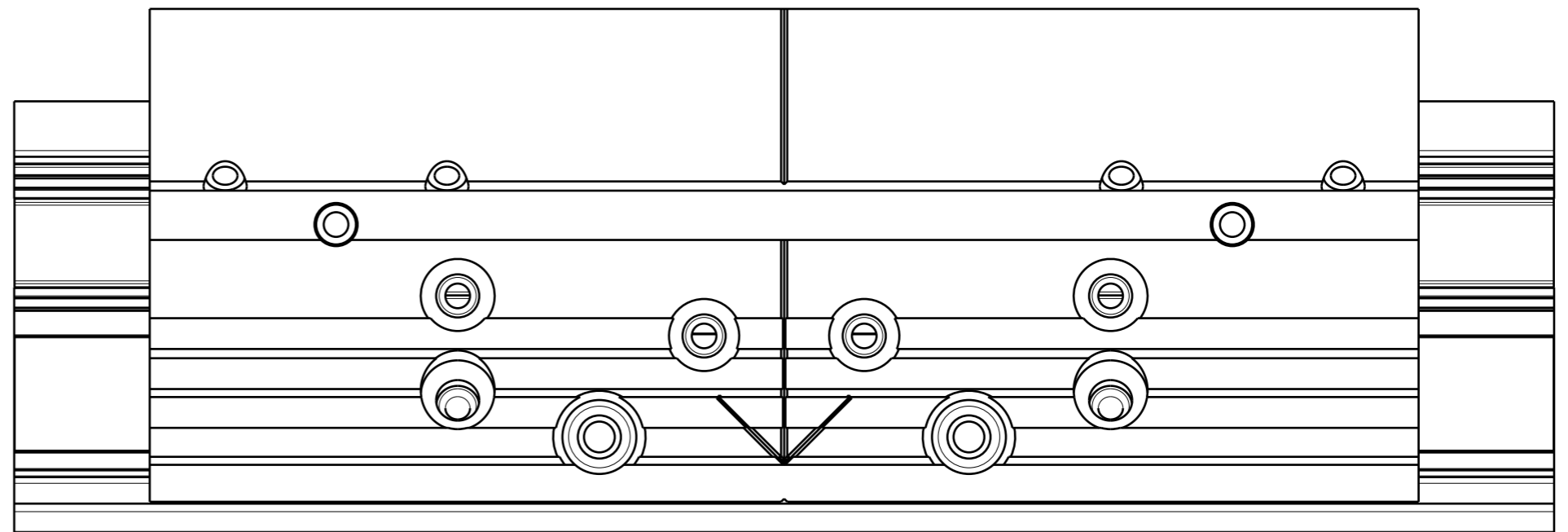
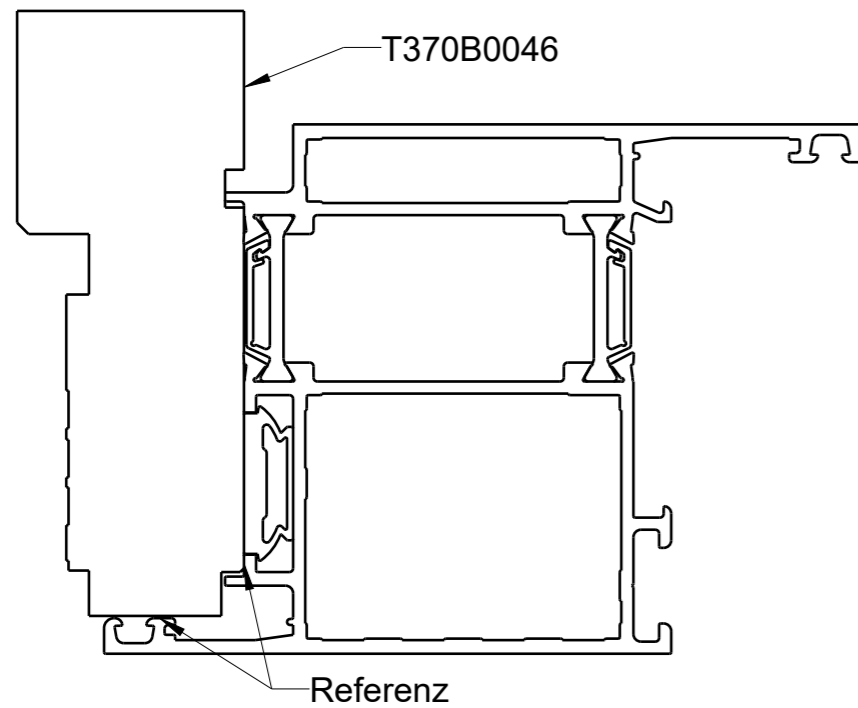
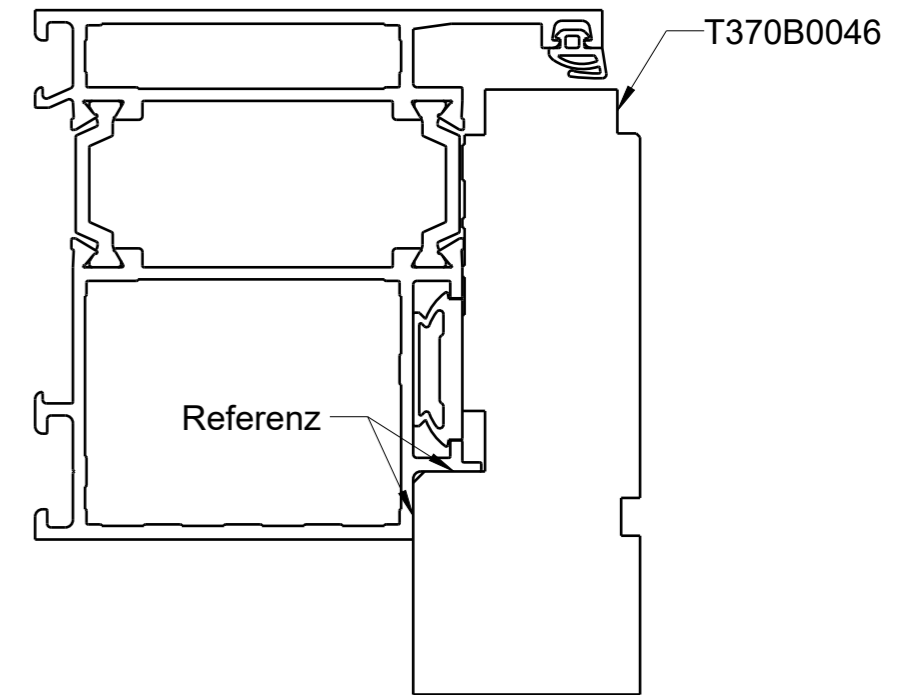
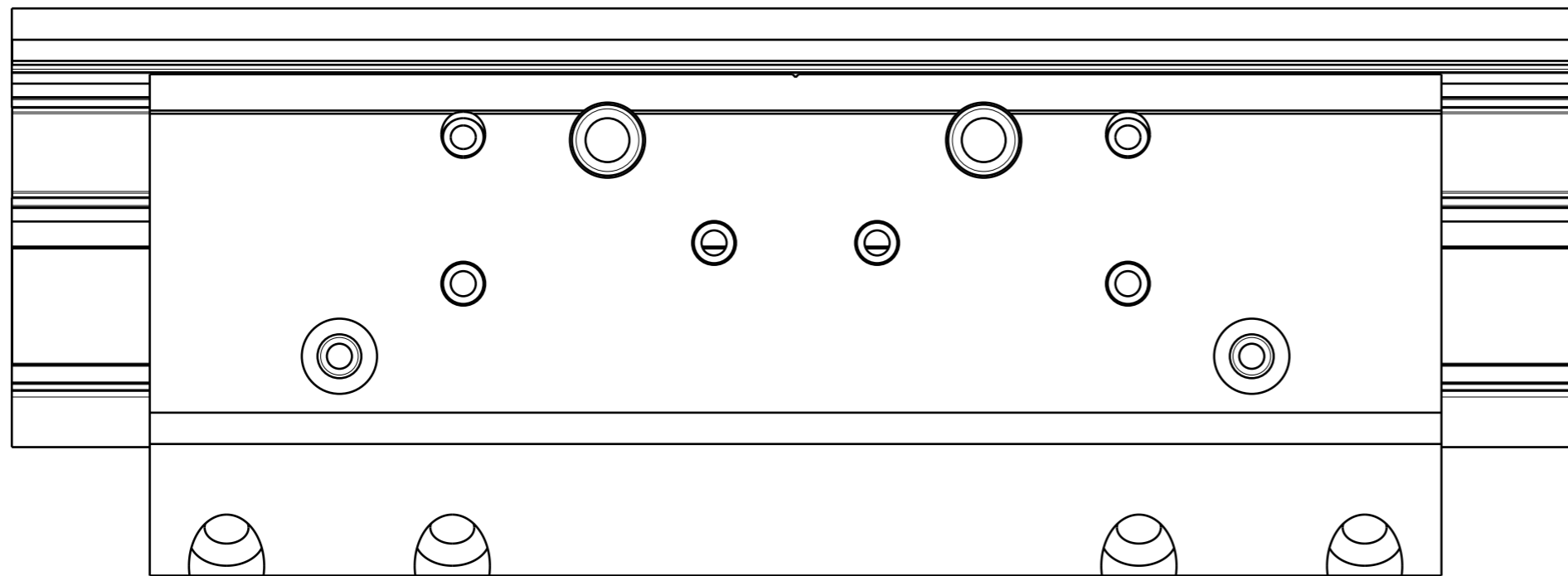

1:2 einwärts öffnende Tür Flügel

Interne Informationen:

1:2 auswärts öffnende Tür Flügel

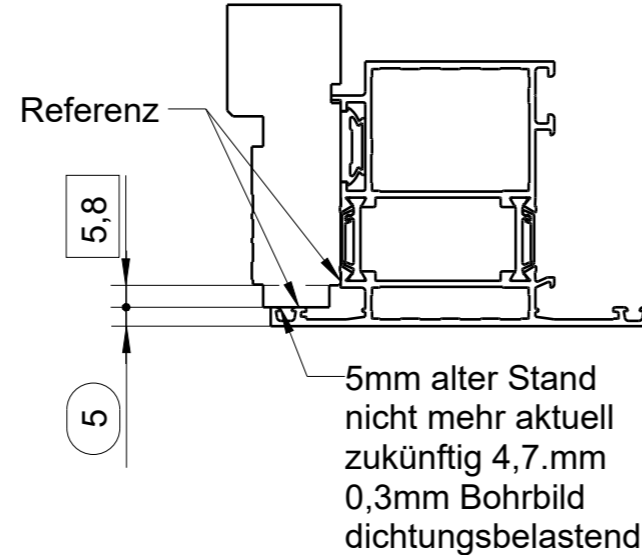
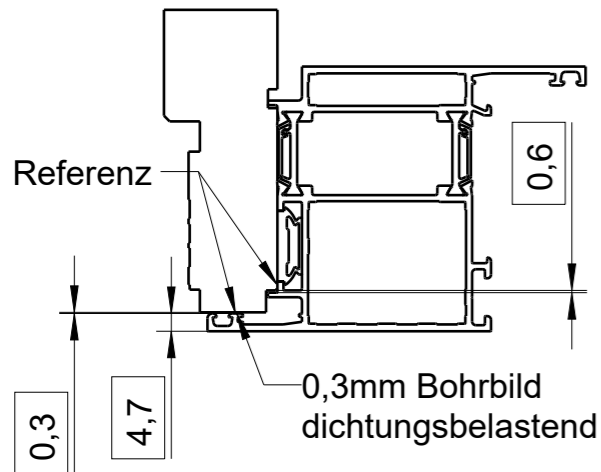

Für diese technischen Unterlagen behalten wir uns alle Rechte nach DIN ISO 16016 vor				Maßstab: 1:1		Gewicht: g	
				Maße ohne Toleranzangabe nur zur Information			
				Benennung:		NICHT Freigegeben!	
				Bear.	13.03.2023	KUDLA	
				Gepr.	13.03.2023	KORP	
				Norm			
				DIS:	121205,ZDR,DRW,00		
				Dr. Hahn [®]		Zeichnungsnummer:	
				TÜRBÄNDER. MADE IN GERMANY.		Blatt	
				R751_TS01_GEN		7	
				7			
In.	Änderung	Datum	Name	Urspr.:	Ers.f.	Modell-Nr. R751_TS01_GEN	