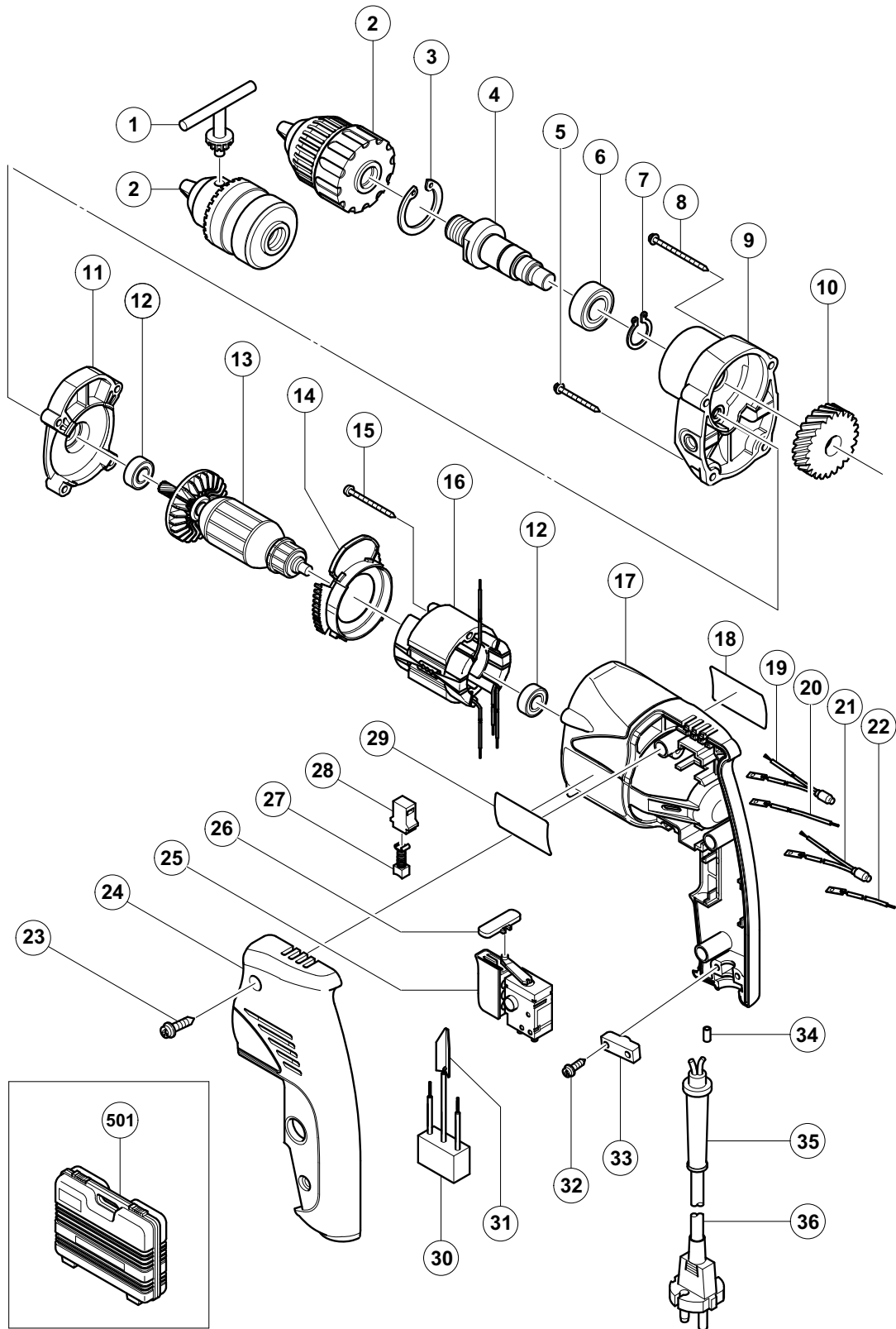

ELECTRIC TOOL PARTS LIST

DRILL

2002 · 12 · 10

Model D 10VC2**(E1)**

PARTS

D 10VC2

ITEM NO.	CODE NO.	DESCRIPTION	NO. USED	REMARKS
* 1	980-057	CHUCK WRENCH 10TL2	1	FOR HKG, NZL, FIJ, HOL
* 2	950-292	DRILL CHUCK 10TLRA	1	INCLUD. 1 FOR HKG, NZL, FIJ, HOL
* 2	312-516	DRILL CHUCK 10TLRD-N (W/O CHUCK WRENCH)	1	EXCEPT FOR NZL, FIJ
3	948-001	RETAINING RING FOR D32 HOLE	1	
4	321-626	SPINDLE	1	
5	305-490	TAPPING SCREW (W/FLANGE) D4X30 (BLACK)	2	
6	600-2VV	BALL BEARING 6002VVCMP2L	1	
7	939-544	RETAINING RING FOR D15 SHAFT (10 PCS.)	1	
8	301-815	TAPPING SCREW (W/FLANGE) D4X45	2	
9	321-625	GEAR COVER	1	
10	321-627	GEAR	1	
11	321-624	INNER COVER	1	
12	608-VVM	BALL BEARING 608VVC2PS2L	2	
* 13	360-596C	ARMATURE 110V	1	
* 13	360-596G	ARMATURE 220V	1	
* 13	360-596E	ARMATURE 230V-240V	1	
14	321-623	FAN GUIDE	1	
15	950-514	TAPPING SCREW D4X40	2	
* 16	340-547C	STATOR 110V	1	
* 16	340-547G	STATOR 220V	1	
* 16	340-547E	STATOR 230V	1	
* 16	340-547F	STATOR 240V	1	
17	321-622	HOUSING	1	
* 18		NAME PLATE	1	
* 19	321-633	CHOKE COIL (BROWN) 110V-240V	1	EXCEPT FOR SIN, MAL, SRI, HKG
* 20	321-630	INTERNAL WIRE (BROWN) 100L	1	FOR SIN, MAL, SRI, HKG
* 21	321-634	CHOKE COIL (BLUE) 110V-240V	1	EXCEPT FOR SIN, MAL, SRI, HKG
* 22	321-631	INTERNAL WIRE (BLUE) 55L	1	FOR SIN, MAL, SRI, HKG
23	301-653	TAPPING SCREW (W/FLANGE) D4X20 (BLACK)	3	
24	321-629	HANDLE COVER	1	
25	321-632	SWITCH (1P PILLAR TYPE)	1	
26	321-628	PUSHING BUTTON	1	
27	999-041	CARBON BRUSH (1 PAIR)	2	
28	955-203	BRUSH HOLDER	2	
29		HITACHI LABEL	1	
* 30	994-273	NOISE SUPPRESSOR	1	EXCEPT FOR SIN, MAL, SRI, HKG
* 31	992-635	EARTH TERMINAL	1	EXCEPT FOR SIN, MAL, SRI, HKG
32	984-750	TAPPING SCREW (W/FLANGE) D4X16	2	
33	937-631	CORD CLIP	1	
* 34	981-373	TUBE (D)	2	FOR CORD
35	953-327	CORD ARMOR D8.8	1	
* 36	500-409Z	CORD	1	(CORD ARMOR D8.8)
* 36	500-423Z	CORD	1	(CORD ARMOR D8.8) FOR SIN, MAL, SRI
* 36	500-439Z	CORD	1	(CORD ARMOR D8.8) FOR NZL, FIJ, AUS
* 36	500-435Z	CORD	1	(CORD ARMOR D8.8) FOR HKG, GBR (230V)
* 36	500-237Z	CORD	1	(CORD ARMOR D8.8) FOR GBR (110V)
* 36	500-247Z	CORD	1	(CORD ARMOR D8.8) FOR FIN, NOR
* 36	500-447Z	CORD	1	(CORD ARMOR D8.8) FOR SUI

STANDARD ACCESSORIES

D 10VC2

ITEM NO.	CODE NO.	DESCRIPTION	NO. USED	REMARKS
* 501	321-635	CASE	1	FOR SIN, MAL, SRI, NZL, FIJ, GBR, FRA, FIN, NOR

OPTIONAL ACCESSORIES

ITEM NO.	CODE NO.	DESCRIPTION	NO. USED	REMARKS
601	982-593	HOOK	1	
602	321-612	HOOK (A)	1	
603	981-205	SIDE HANDLE FOR M10	1	

