

Service Manual

Cordless Rotary Hammer Drill & Driver

EY6803-X8

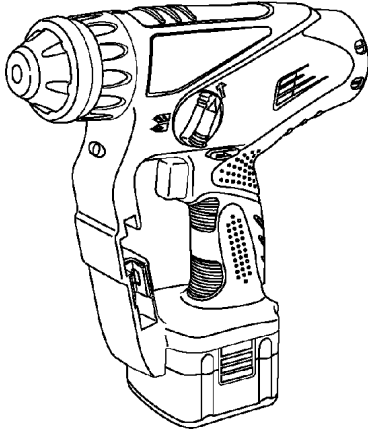

SPECIFICATIONS

Maximum drilling diameter	Concrete	ϕ 10mm (25/64") – 12.5mm (15/32")* * For work that can be completed with one battery pack.
	Steel	13mm (33/64")
Motor voltage	12V DC	
Speed at no load (RPM)	0 ~ 1000/min (rpm)	
Blows rate per minute (BPM)	Soft Mode	0 ~ 4000/min (bpm)
Weight (with battery pack)	2.5kg (5.5lbs.)	
Dimensions (LxWxH)	249x257x64mm (10"x10-1/8"x2-1/2")	

⚠ WARNING

This service information is designed for experienced repair technicians only and is not designed for use by the general public. It does not contain warnings or cautions to advise non-technical individuals of potential dangers in attempting to service a product. Products powered by electricity should be serviced or repaired only by experienced professional technicians. Any attempt to service or repair the product or products dealt with in this service information by anyone else could result in serious injury or death.

CONTENTS

	Page		Page
1 SCHEMATIC DIAGRAM	2	5 TRIAL OPERATION (after checking TROUBLESHOOTING GUIDE.)	10
2 WIRING CONNECTION DIAGRAM	2	6 EXPLODED VIEW	11
3 DISASSEMBLY/ASSEMBLY INSTRUCTIONS	3	7 REPLACEMENT PARTS LIST	12
4 TROUBLESHOOTING GUIDE	7		

Panasonic

© 2006 Matsushita Electric Works Ltd. All rights reserved. Unauthorized copying and distribution is a violation of law.

1 SCHEMATIC DIAGRAM

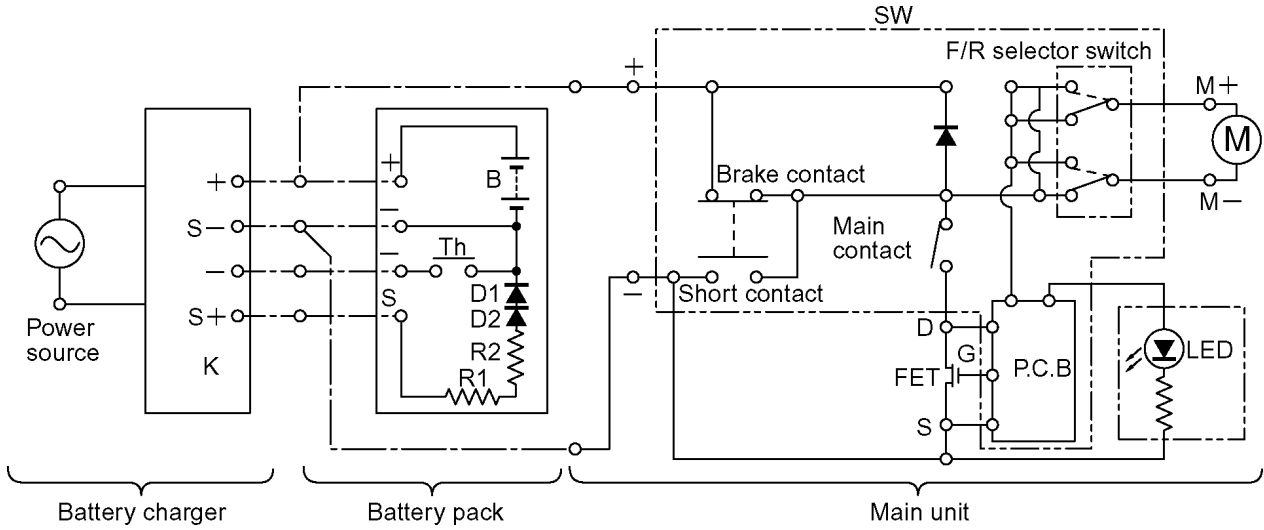

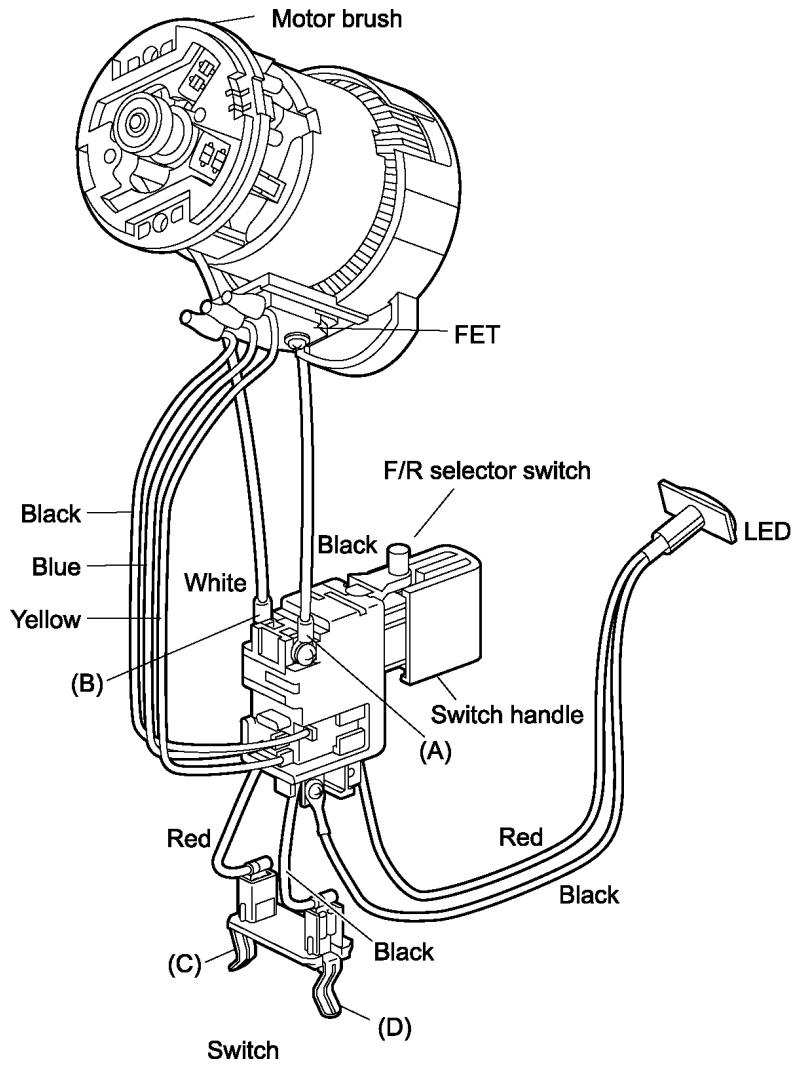

2 WIRING CONNECTION DIAGRAM

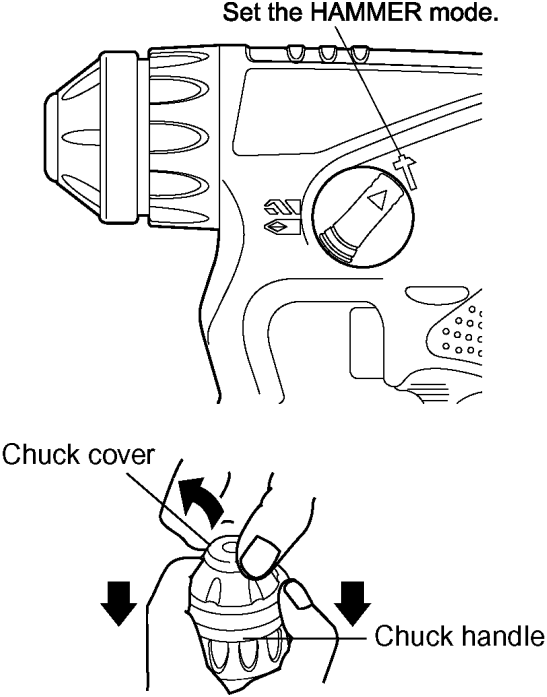

3 DISASSEMBLY/ASSEMBLY INSTRUCTIONS

■HOW TO DISASSEMBLE THE MAIN UNIT.

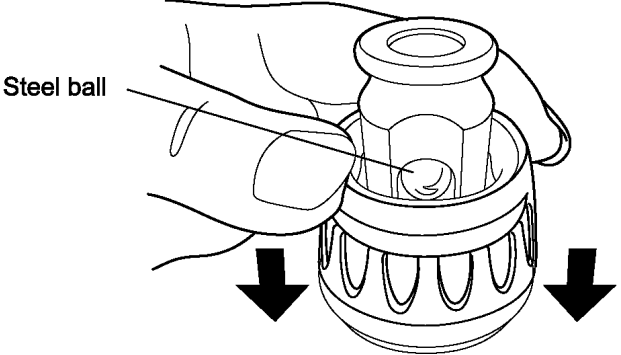
Ref. No. 1A	Procedure 1A	Removal of the chuck handle.
		<ol style="list-style-type: none"> 1. Set the hammering/drilling switching lever to the position . 2. Pluck the chuck cover depressing the chuck handle. 3. Remove the chuck handle. 4. Take out a steel ball pushing the chuck spring with the chuck spring plate. 5. Remove the chuck spring plate and the chuck spring. 

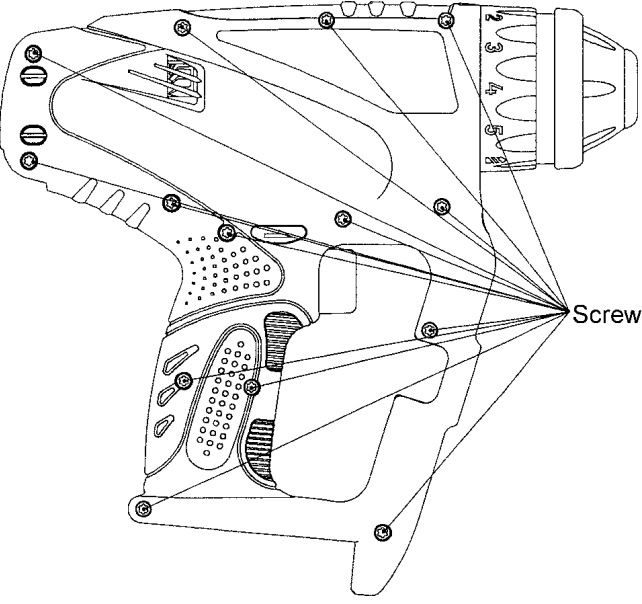
Ref. No. 1B	Procedure 1A→1B	Removal of the housing.
		<ol style="list-style-type: none"> 1. Remove 14 housing screws.

■HOW TO DISASSEMBLE THE MOTOR AND SWITCH.

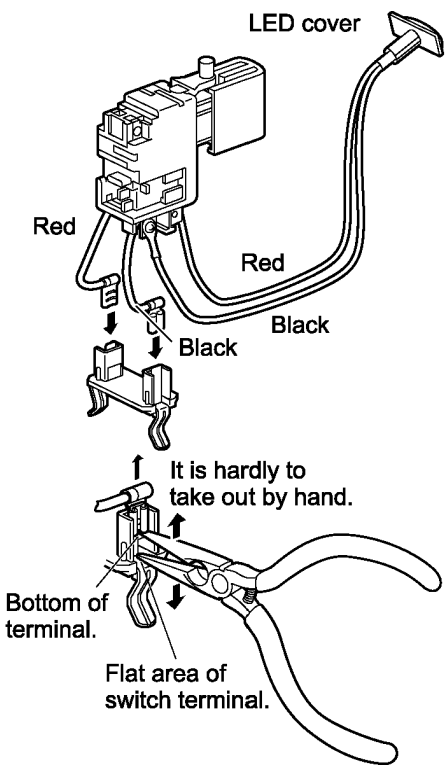
Ref. No. 2A	Procedure 1A→1B→2A	Removal of the switch.
 <p>LED cover</p> <p>Red</p> <p>Red</p> <p>Black</p> <p>Black</p> <p>It is hardly to take out by hand.</p> <p>Bottom of terminal.</p> <p>Flat area of switch terminal.</p> <p>breakage</p>		<p>Removal of the switch.</p> <ol style="list-style-type: none"> 1. Take out the switch and the base plate assembly from the housing. 2. Take out the LED cover. <p>For assembling</p> <p>NOTE:</p> <p>Do not push the area where marked the arrow in order to prevent the breakage.</p>

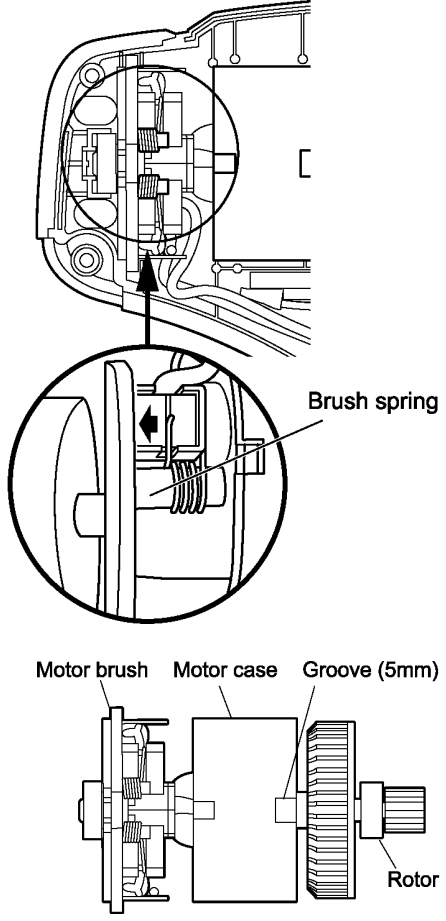
Ref. No. 2B	Procedure 1A→1B→2A→2B	Removal of the motor assembly.
 <p>Brush spring</p> <p>Motor brush</p> <p>Motor case</p> <p>Groove (5mm)</p> <p>Rotor</p>		<p>Removal of the motor assembly.</p> <ol style="list-style-type: none"> 1. Hitch the brush spring to the frame by something like a forceps and take the motor brush assembly with the switch out from the motor assembly. 2. Take out the rotor and the current plate from the motor case. <p>For assembling</p> <p>NOTE:</p> <p>Make sure to return the spring into the groove of the motor brush.</p> <p>Make sure to set the 5mm of groove of motor case on the hammer side.</p> <p>Close the housing and try to apply the DC12V and check if the motor rotates or not.</p>

■HOW TO DISASSEMBLE THE DRIVING BLOCK.

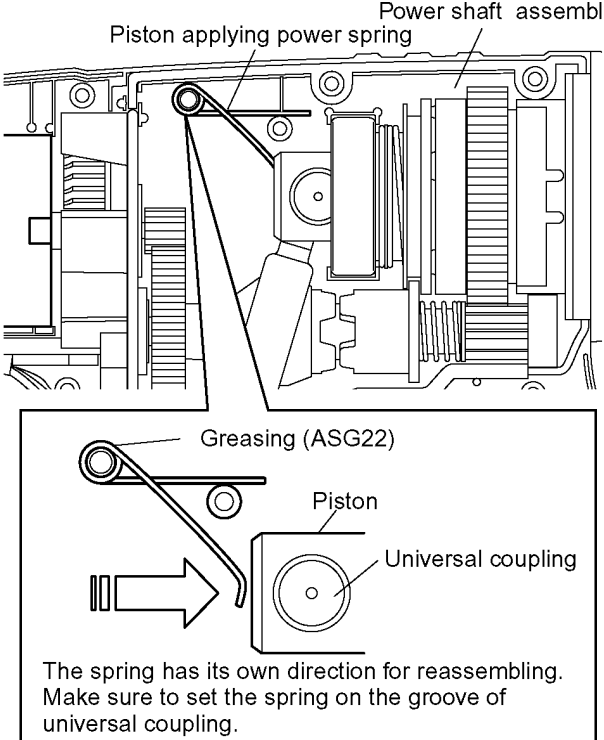
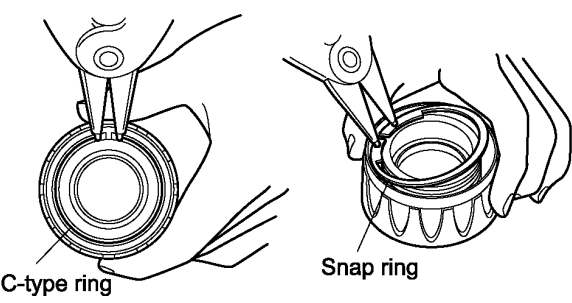
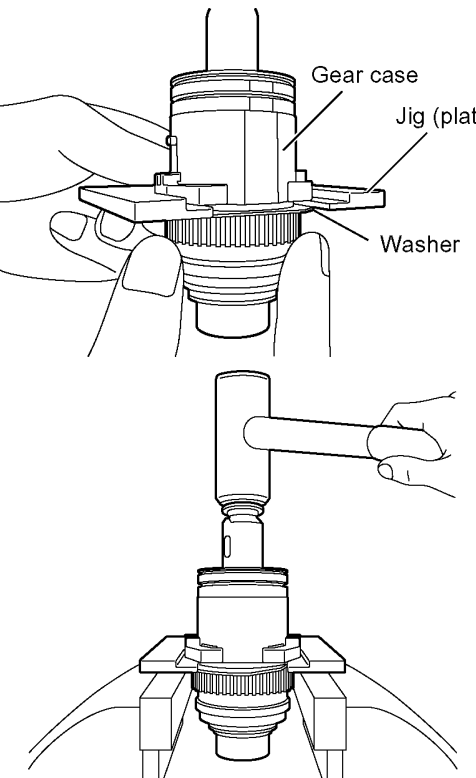
Ref. No. 2C	Procedure 2A → 2B → 2C	Removal of the power shaft assembly.
 <p>The spring has its own direction for reassembling. Make sure to set the spring on the groove of universal coupling.</p>		<ol style="list-style-type: none"> 1. Remove the piston applying power spring. 2. Take out the power shaft assembly. 3. Remove the c-type ring, felt and snap ring. 4. Remove the clutch handle with pins and the thrust plate. 5. Remove the snap ring. 6. Slide the jig (plate) into between the washer and the gear case and hold it by a vise. 7. Tap the top of spindle block with a plastic hammer to take out the spindle and clutch block assembly. 8. Take out the snap ring on the rear side of the bearing. 9. Take out two pins by using absorption force about 30N magnet from the clutch block. 10. Take out four steel balls and remove the spindle & piston assembly. 11. Remove the striker with the O-ring and the O-ring. And take out the bearing. 12. Take out the piston block. And take out the piston and the universal coupling. 13. Remove the intermediate shaft assembly.
 <p>C-type ring Snap ring</p>		
 <p>Gear case Jig (plate) Washer</p>		

Ref. No. 2D

Procedure 2A → 2B → 2C → 2D

Attachment of driving block.

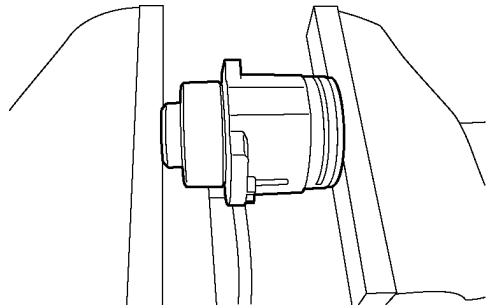
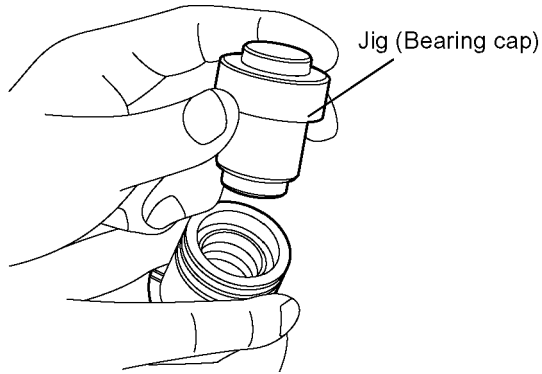
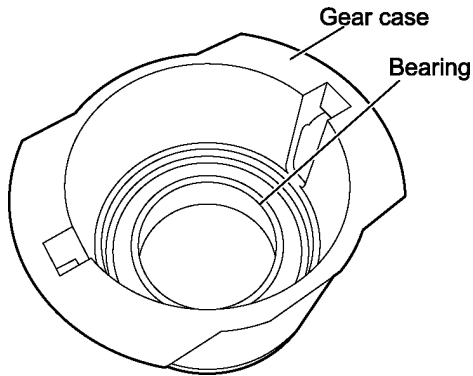

Bearing has its own direction for reassembling.

Make sure to align between the projection of the reciprocation bearing and the changing clutch.

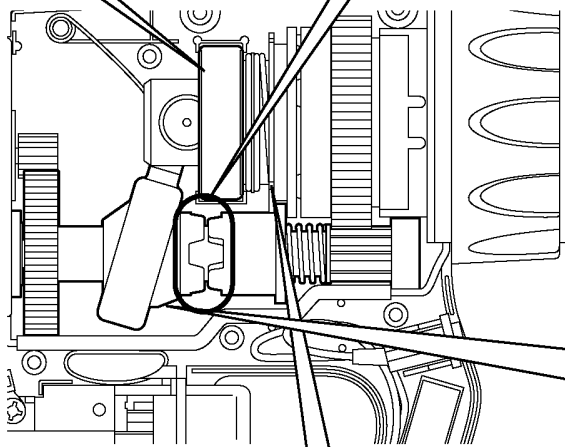

Make sure to set the washer of intermediate shaft assembly into the groove of the spindle assembly.

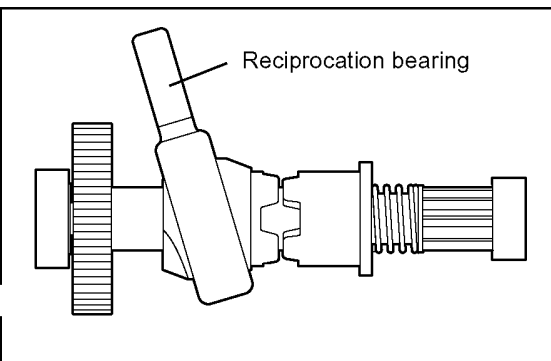
**For assembling**

1. Set the jig (bearing cap) into the clutch case and hold it with a vise in order to take out the bearing.
2. Assemble the bearing with the spindle assembly.
3. Set the snap ring.

NOTE :

It has own direction for reassembly. Place the rounded face of snap ring to the clutch case side.

4. Fit O-ring onto the bearing.
5. Assemble the chuck spring and the chuck spring plate.
6. Insert a ball pushing down the chuck spring.
7. Insert the reciprocation bearing shaft into the hole of universal coupling. Make sure two thrust plates should be set both side of reciprocation bearing shaft one of each.

NOTE :

Apply grease especially for the connection area between reciprocation bearing and universal coupling. In addition, hammer O-ring, inside of piston and cylinder for output shaft block also need to apply.

Air compressed by the piston drives hammer. Take care to protect the piston and hammer from contamination by dust.

4 TROUBLESHOOTING GUIDE

(Refer to WIRING CONNECTION DIAGRAM)

4.1. CHECK POINTS FOR ELECTRICAL PARTS.

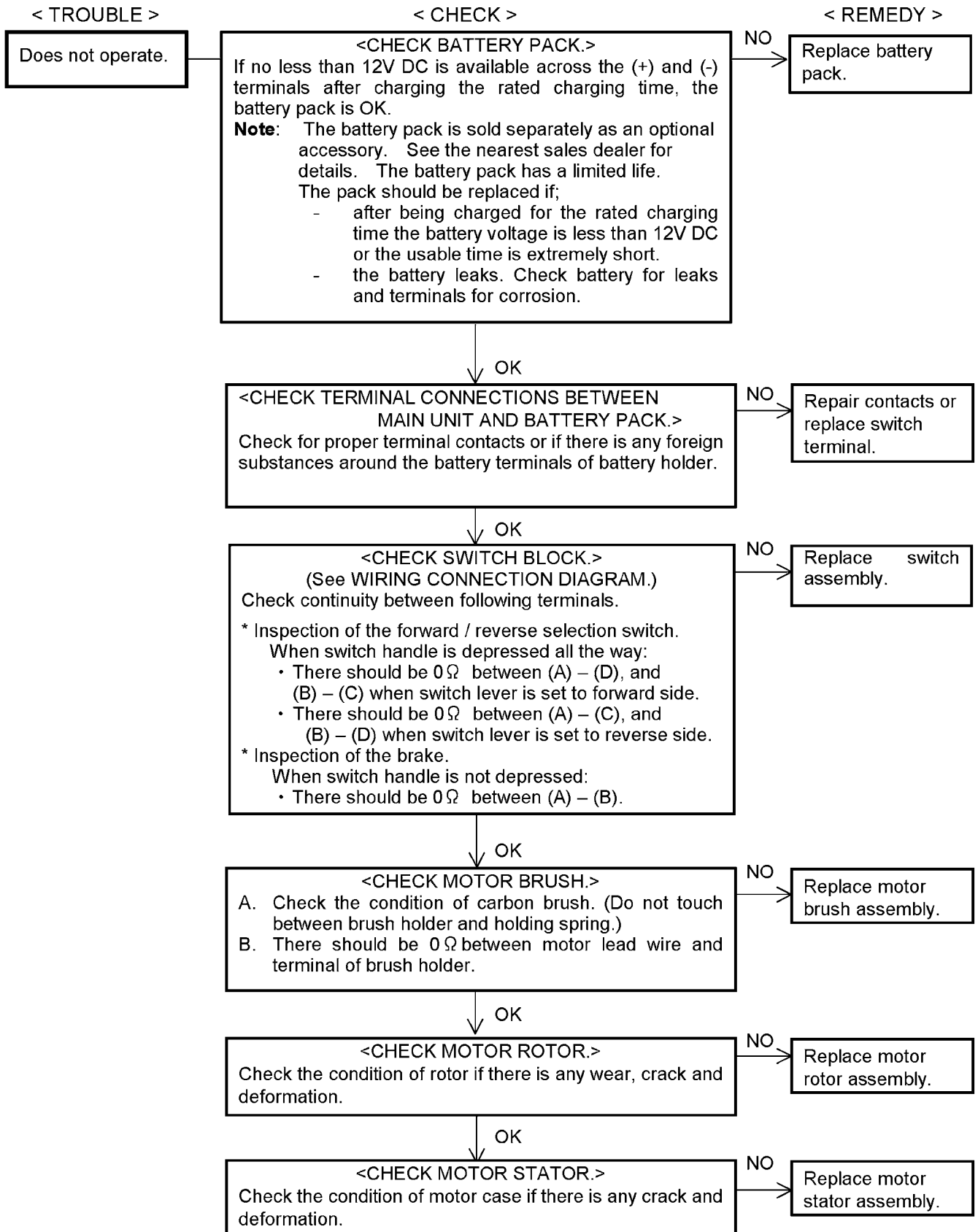

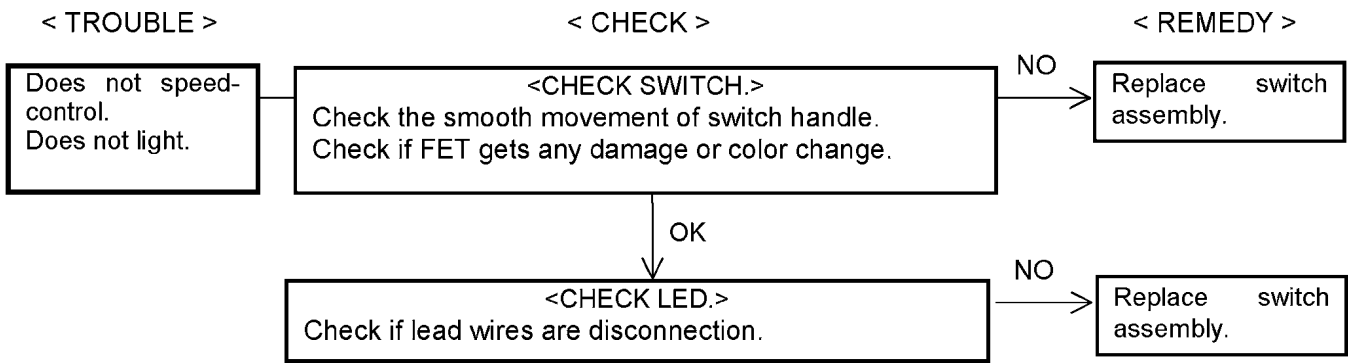

4.2. CHECK POINTS FOR MECHANISM BLOCK.

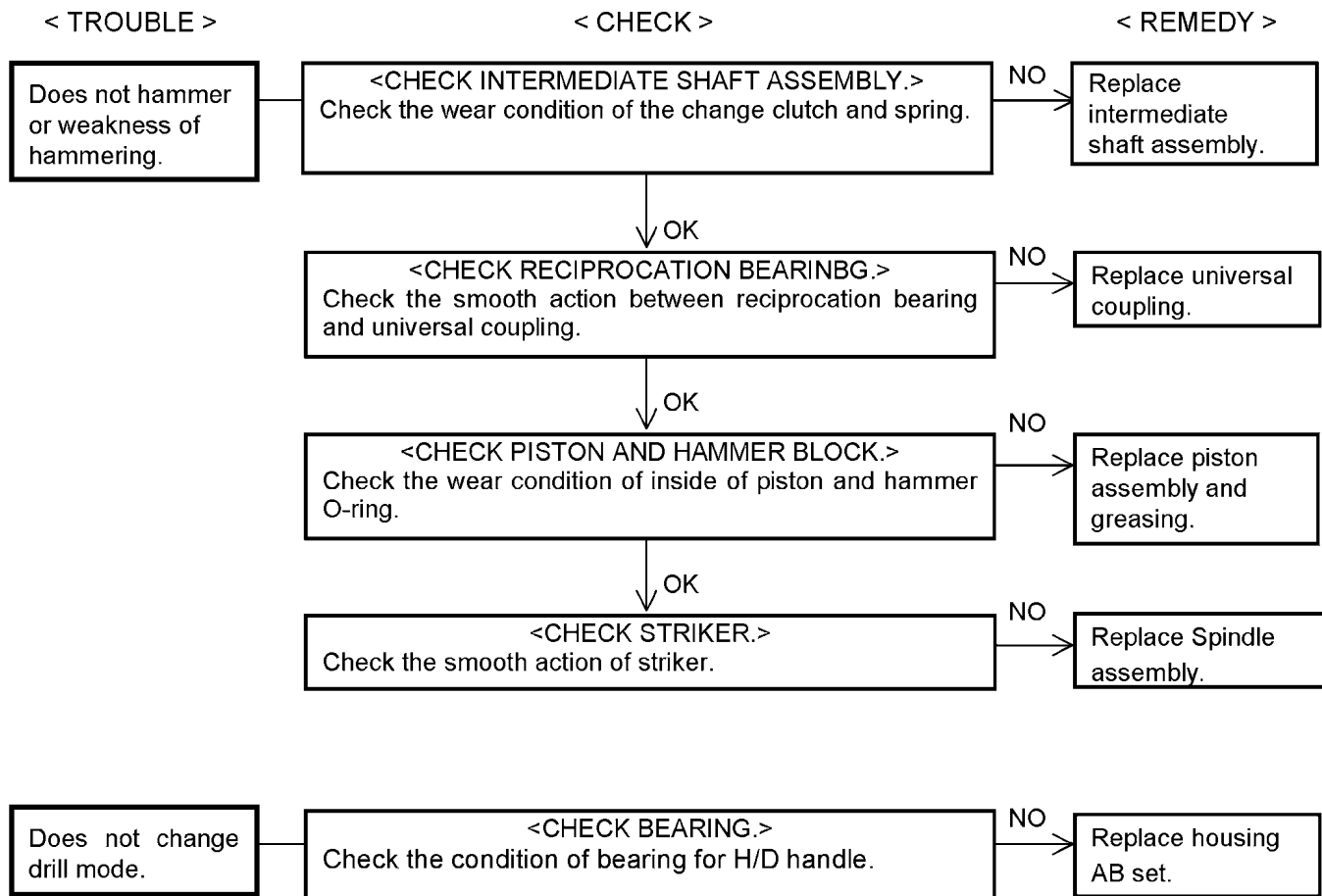

< TROUBLE >

< CHECK >

< REMEDY >

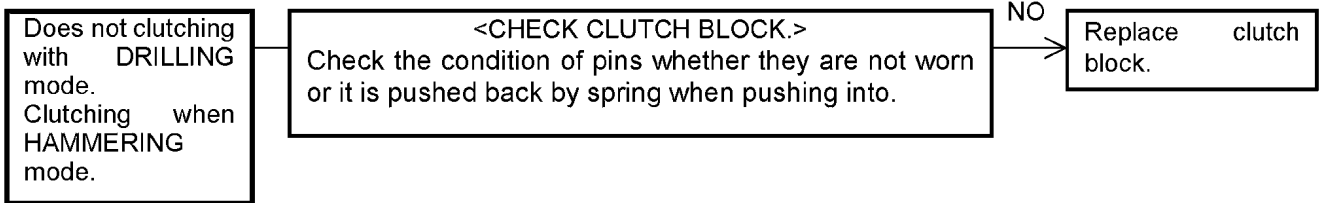
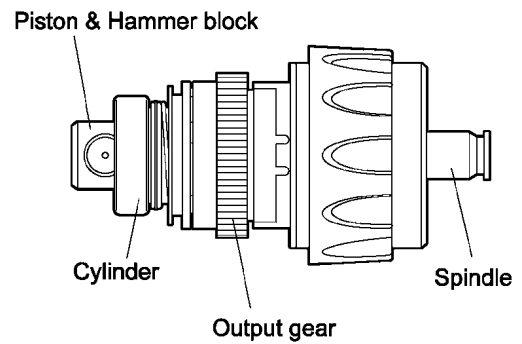
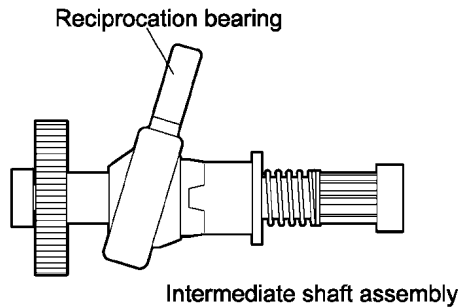
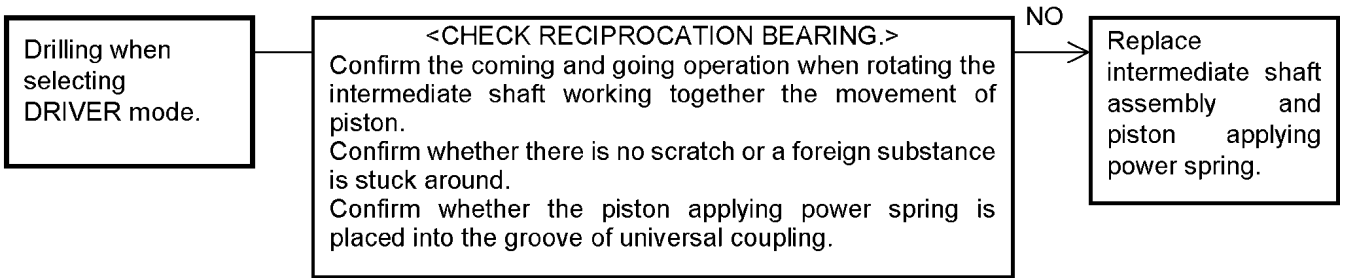
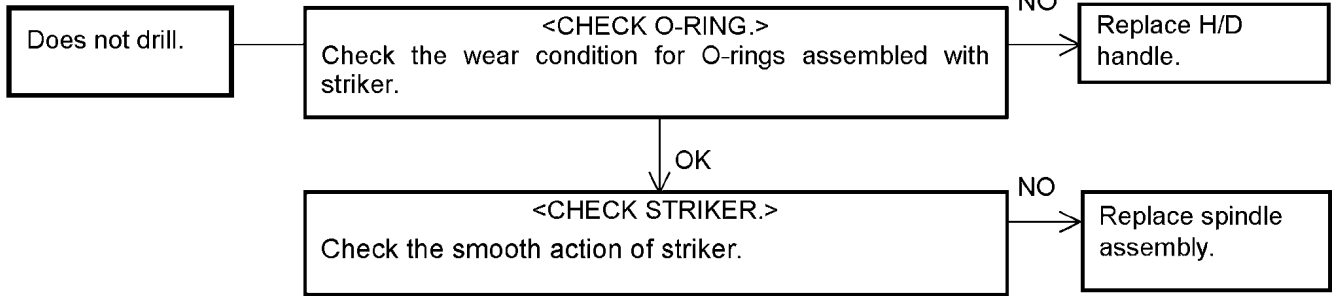

5 TRIAL OPERATION (after checking TROUBLESHOOTING GUIDE.)

5.1. HAMMER/DRILL

Confirm the action when setting the H/D handle to HAMMER mode.

Rotation with hammering when the drill bit touches something like stone, and power.

It is OK, if it takes about 4-6 seconds by 20kgf to hole (ϕ 6X30) on the concrete .

Confirm the action when setting the H/D handle to DRILL mode.

No hammering when the drill bit touches iron plate.

5.2. SWITCH

<SPEED CONTROL>

Change the rotation speed from 0-1000 rpm in proportion to the amount of pushing level on switch trigger.

<LED>

Check if the LED is lits.

5.3. REVERSING LEVER

Confirm the action with setting the reversing lever to FORWARD or REVERSE.

5.4. ASSEMBLY

Confirm pressing the lead wires between ribs, tightening screws firmly.

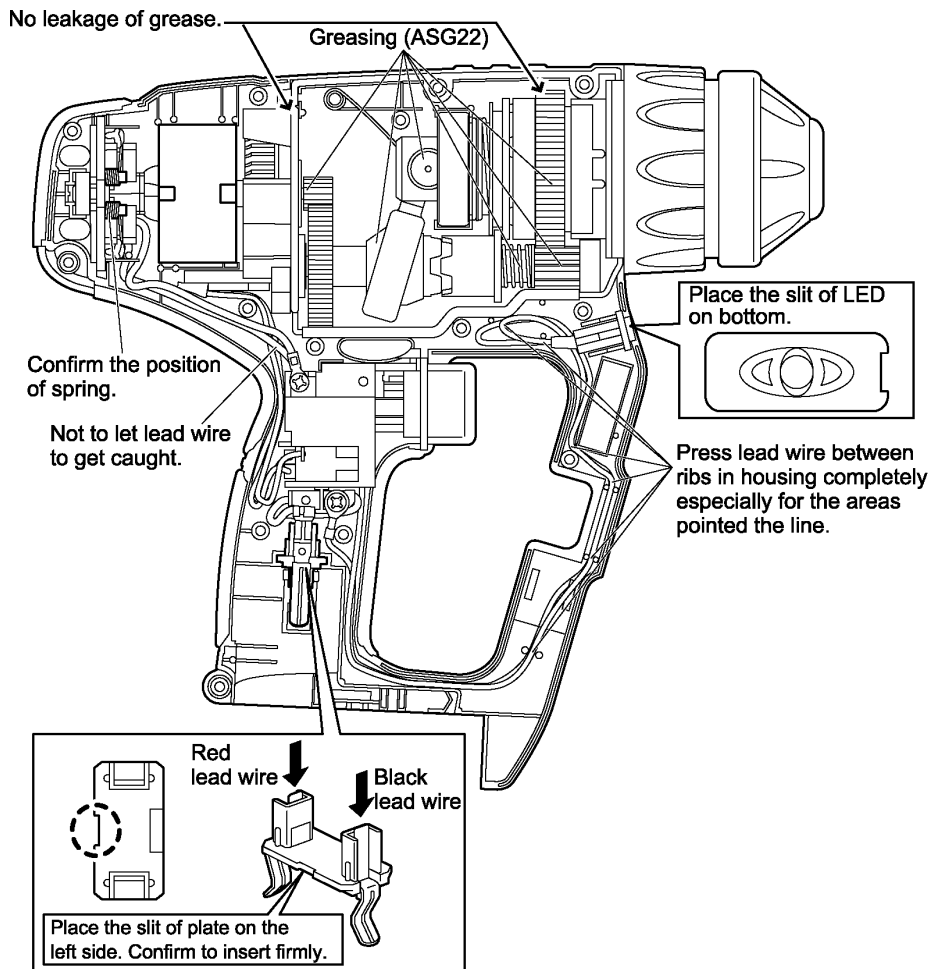

6 EXPLODED VIEW

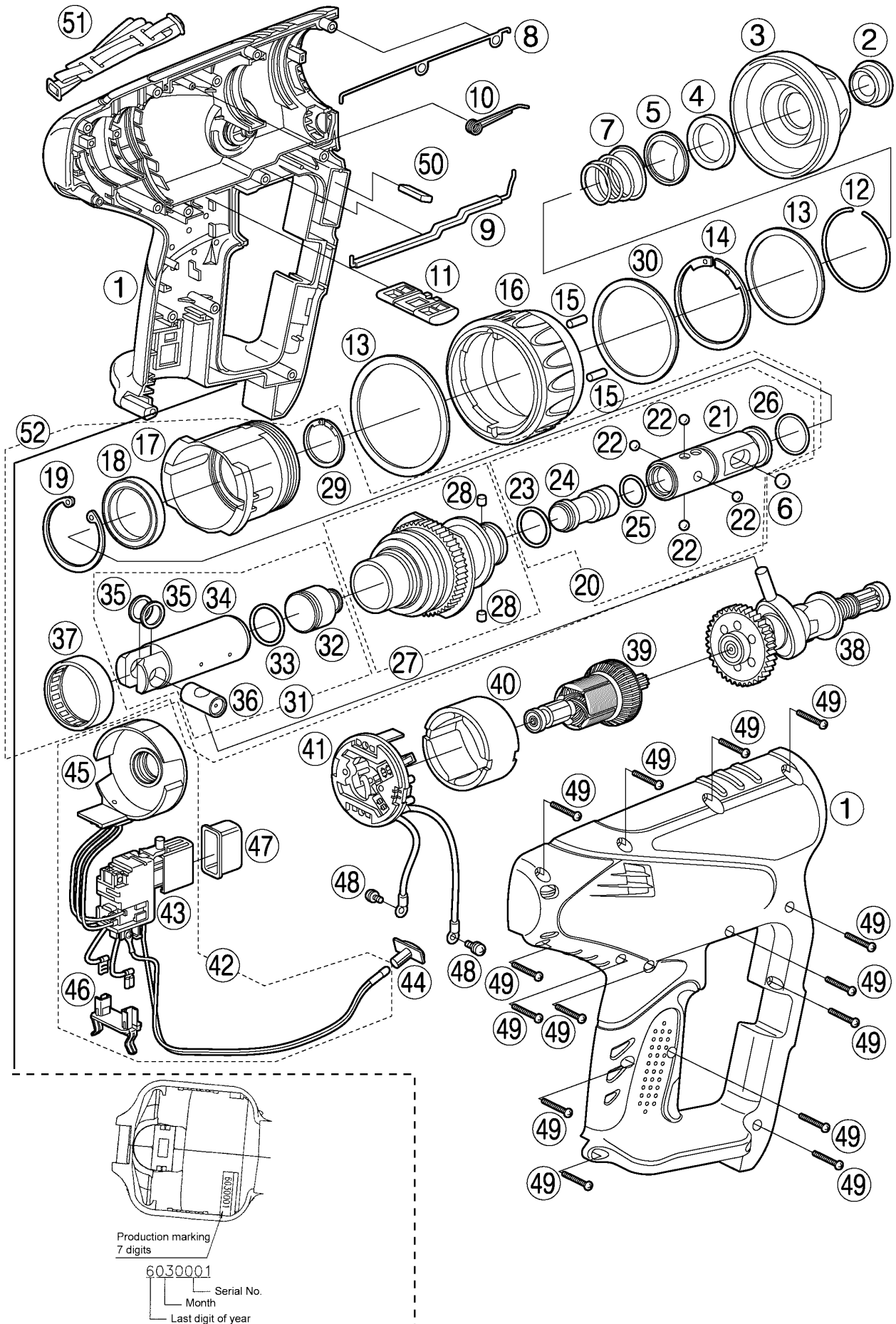

7 REPLACEMENT PARTS LIST

NOTE:

*B=only available as set

*C=available individually

Ref.No.	Part No.	Part Name & Description	Remarks	Per Unit
1	WEY6803K3079	HOUSING AB SET	for EUROPE	1
1	WEY6803K3070	HOUSING AB SET	for OCEANIA	1
2	WEY6813H3116	CHUCK COVER		1
3	WEY6803K3127	CHUCK HANDLE		1
4	WEY6813L0426	BALL GUIDE		1
5	WEY6813L0436	CHUCK SPRING STRIKE PLATE		1
6	WEY6813L1916	STEEL BALL	Ø 7	1
7	WEY6813L0916	CHUCK SPRING		1
8	WEY6803L3997	SEAL A		1
9	WEY6803L3987	SEAL B		1
10	WEY6803L0927	PISTON APPLYING POWER SPRING		1
11	WEY6803Y3247	F/R HANDLE		1
12	WEY6803L1167	C-TYPE RING		1
13	WEY6803L3137	FELT		1
14	WEY6803L0467	SNAP RING		1
15	WEY6803L1707	LOCK PIN	*B (2PCS/PK)	2
16	WEY6803Y3227	CLUTCH HANDLE		1
17	WEY6803Y3297	CLUTCH CASE		1
18	WEY6813L4957	BEARING		1
19	WEY6803L0477	SNAP RING		1
20	WEY6803L4067	SPINDLE ASSEMBLY		1
21	WEY6803L0057	SPINDLE		1
22	WEY6813L1926	STEEL BALL	*B Ø 5, (6PCS/PK)	4
23	WEY6813L0347	O RING		1
24	WEY6803L1237	STRIKER		1
25	WEY6813L0327	O RING		1
26	WEY6813L0317	O RING		1
27	WEY6803L4907	CLUTCH ASSEMBLY		1
28	WEY6813L0907	PIN	*B 5x4, (2PCS/PK)	2
29	WEY6813L0477	SNAP RING		1
30	WEY6803L0857	THRUST PLATE	*C	2
31	WEY6803L1247	PISTON ASSEMBLY		1
32	WEY6803L4627	HAMMER		1
33	WEY6803L0977	O RING		1
34	WEY6803L1987	PISTON		1
35	WEY6812L0847	THRUST PLATE	*B (2PCS/PK)	2
36	WEY6803L1257	UNIVERSAL COUPLING		1
37	WEY6803L0387	NEEDLE BEARING		1
38	WEY6803L4057	INTERMEDIATE SHAFT ASSEMBLY		1
39	WEY6803L1467	MOTOR ROTOR ASSEMBLY		1
40	WEY6803L1187	MOTOR STATOR ASSEMBLY		1
41	WEY6803L2307	MOTOR BRUSH ASSEMBLY		1
42	WEY6803L2007	SWITCH ASSEMBLY		1
43	WEY6803L2017	SWITCH		1
44	WEY6803L2337	LED COVER		1
45	WEY6803L0417	BASE PLATE BLOCK		1
46	WEY6803L2407	TERMINAL BLOCK		1
47	WEY6813L3136	TRIGGER COVER		1
48	WEY6261B6026	SEMS SCREW	*C K3-6	2
49	WEY6230K9216	TORX TAPPING SCREW	*C K3X20	14
50	WEY6803L0137	CUSHION RUBBER		1
51	WEY3561L3417	SHOULDER STRAP		1
52	WEY6803L4538	POWER SHAFT ASSEMBLY		1
-	WEY6811X5537	GREASE	ASG-22	1
-	WEY6812T7916	GREASE		1
-	WEY9629K7018	TOOL CASE		1
-	WEY6803K4968	JIG (PLATE & CAP)		1
-	WEY6803K8109	OPERATING INSTRUCTIONS		1

** Battery Pack and Bit Adaptor are available as an optional accessory. .

See the nearest sales dealer for details.

*** For replacement parts of charger, see the charger service manual.

Charger complete set is available as an optional accessory. See the nearest sales dealer for details.